



EcoOnline - Vertex™ Flood-Prime

Solar Pool & Spa Heating System

Installation & User Manual – Revised 4/11/2023



Optex Solar Pty. Ltd.

ABN: 88 128 228 884

www.EcoOnline.com.au

email: info@EcoOnline.com.au

© Copyright 2023 Optex Solar Pty Ltd. All rights strictly reserved. This publication is protected by copyright law and unless otherwise specified is for your personal and non-commercial use only. No part of this publication may be reproduced or distributed by any process, electronic or otherwise, without the specific written permission of Optex Solar Pty Ltd. Trademarks appearing in this manual are the sole property of Optex Solar Pty Ltd or their respective owners. Nothing in this publication shall be construed as granting any express or implied license to use any intellectual property of Optex Solar Pty Ltd otherwise than for personal and non-commercial use only. Optex Solar Pty Ltd must not, to the full extent permitted by law, be held liable for any claim, cost (including legal costs), damage, expense, loss (including fines, penalties, set-offs and consequential loss) or liability arising from the use (or misuse) of any product described in this publication, unless expressly provided otherwise in this publication. Information as well as any products described in this publication are subject to change without notice.

Contents

- 1 Key Terms**
- 2 Pre-Installation Suitability & Safety Checklist**
- 3 Warranties**
- 4 System Sizing Guarantee**
- 5 Collector and Solar Pump Sizing Guide**
- 6 Spa Chemistry Compatibility Guide**
- 7 Roof Type Compatibility Guide**
- 8 Wind and Climate Considerations**
- 9 Included System Components**
- 10 Additional Required Components (Not Supplied)**
 - 10.1 Ground Mounting Support Frame
 - 10.2 Roof Mounting
 - 10.3 Additional Plumbing Components
- 11 Required Tools**
- 12 Safety When Working at Heights**
 - 12.1 Ladder Safety
- 13 Choosing A Place to Install the Collector Array**
- 14 Pump and Solar PV Panel Test**
 - 14.1 What if the Pump Won't Start?
- 15 Collector Array Configurations**
 - 15.1 Array Configurations Not Recommend
- 16 Roof Attachment Options**
 - 16.1 Tile Roof Mounting Frame
- 17 Corrugated Metal Roof Aluminium Angle Mounting Options**
 - 17.1 Aluminium Angle Mounting Options
 - 17.2 Thermal Expansion Gaps for Aluminium Channels
 - 17.3 Metal Roof Screw Selection and Method
- 18 Collector Mounting Procedure**
- 19 Collector Array Plumbing Connections**
- 20 Roof Fixings**
 - 20.1 Application of the PVC Coated Stainless Steel Straps
 - 20.2 Single or Multi-Row Metal Roof Fixings Wind Region A
 - 20.3 Single or Multi-Row Metal Roof Fixings for Wind Regions B & C
 - 20.4 Single or Multi-Row Tile Roof Fixings for Wind Region A & B
 - 20.5 Perforated Band Under-Tile Anchor Point (For Region B or Two row arrays)

21 Wind Proofing

- 21.1 Ultimate Peak Wind Loadings per Panel
- 21.2 Frequency of Extra Fixings for Different Regions
- 21.3 Wind Region Definitions
- 21.4 Terrain Category Definitions
- 21.5 Roof Edge Exclusions Zones

22 Plumbing Diagram

23 Suction Line / Pump / By-Pass Line / Bubble Chamber Configuration

- 23.1 Installation of the By-Pass Ports and Line
- 23.2 Suction Plumbing Configurations Not Allowed

24 Different Plumbing Situations

- 24.1 From Spa to Roof Collector Plumbing Setup
- 24.2 From Spa to Ground Run to Roof Collector Plumbing Setup (Extra Vac Valve Required)
- 24.3 From Spa to Ground Mounted Collector Plumbing Setup

25 Allowable Plumbing Variations

- 25.1 Dual Pump Setups

26 Solar PV Panel Mounting

- 26.1 Solar PV Panel Location
- 26.2 Extending the Electrical Wires

27 Installing the Over-Temperature Thermostat

- 27.1 Adjusting the Spa Temperature

28 Connecting the Inline Over-Temperature Thermostat and Extension Wire

29 Switching the System ON for the First Time

- 29.1 Check for Balanced Water Flow through All Collectors
- 29.2 Air Bubbles in the Return Port

30 Important Installation Check List

31 Further Operating Instructions

- 31.1 Legionaries Risk

32 Service and Maintenance Schedule

- 32.1 Collector Puncture Repair Procedure

33 Trouble Shooting

1 Key Terms

This manual was written to follow guidelines and recommendations given in:

- AS 3634 - 1989 Solar heating systems for swimming pools
- AS 1170.2 - 2011 (Amend 2 Dec 2012) Structural design actions - Wind actions
- 'HAZPAK' produced by the work-cover authority
- AS 3000 (2007) Sections 6.3, 6.4 & 6.5
- AS 1926.1 & 1926.2 (2007) swimming pool safety - location of safety barrier

Please print this manual out and keep it for your reference. Please take the time to read the entire manual before starting any work. Particular attention should be given to text contained in the following key terms.

Please note EcoOnline has a strong product safety policy; do not install products without reading safety guidelines in the manual. Please report any product safety issues or near misses to info@EcoOnline.com.au no matter how trivial.



DANGER

Indicates a **SAFETY** issue that **is likely to** cause injury or death if the user does not follow the instructions.



WARNING

Indicates a **SAFETY** issue that **may** cause injury or death if the user does not follow the instructions.



CAUTION

Indicates an issue that **may** cause system component damage if the user does not follow the instructions.



Read Carefully

Refers to **critically important** information related to the **correct functioning** of the system.



Tip

Refers to useful information for the **optimal operation** of the system

2 Pre-Installation Suitability & Safety Checklist

The following outlines mandatory suitability and safety requirements for installing a Vertex Solar™ heating system. Please read carefully, if any of the following requirements cannot be met a Vertex system should NOT be purchased or installed.



DANGER

For ground level collector installations the installer **MUST** check child safety fence regulations in the relevant state. Under no circumstances should collectors be installed so as to compromise the effectiveness of a child pool or spa fence safety barrier by providing a climbable object.



DANGER

Due to the potential of falling from heights, mounting the solar panels on a roof or structure at heights should only be undertaken by a professional solar panel installer, unless you are accustomed to and confident of performing the work safely.



WARNING

Due to the remote possibility of a water drain down event caused by the Vertex system, this system should not be installed on a pool or spa pool with a mains power electrical device that **does not have a working over temperature protection device and/or will not fail safely in the event of dry running.**



WARNING

This appliance is not intended for use by persons (including children) with reduced physical, sensory or mental capabilities, or lack of experience and knowledge, unless they have been given supervision or instruction concerning use of the appliance by a person responsible for their safety. Children should be supervised to ensure that they do not play with the appliance.



WARNING

The safety over-thermostat **MUST** be installed for systems involving an oversized collector array greater than 100% pool coverage area or for highly insulated spa pools due to the potential for overheating in summer.



WARNING

At present this collector array system is **not recommended for exposed installations in cyclonic regions C or D, or on houses situated on top of hills in cyclonic region B, or on second story (or higher) roofs.** Installations on tiles are for Wind Region A only.



CAUTION

The Vertex system is for heating **outdoor chlorinated or otherwise treated spas ONLY.** This system is **not to be used to heat indoor spas** (chlorinated or otherwise) OR **fresh** bodies of water due to the potential for Legionaries bacteria build up.



CAUTION

Potential flooding resulting from the failure of the Vertex systems plumbing connections or extreme weather events must be considered by the purchaser/installer, such that flood water from such a failure at any point of a Vertex system will drain safely.



CAUTION

Building regulations vary from state to state and **MUST** override any instructions supplied in the Vertex system manual. It is the responsibility of the purchaser/installer to check that installations comply with any relevant state laws and regulations.



Read Carefully

The Vertex System is not self-priming and requires the installation of the pump outside of but **below** the waterline of your pool/spa.



Read Carefully

The Vertex System requires the installation of an independent suction line; **Teeing into the mains pump filter circuit is not allowed.**

3 Warranties

EcoOnline™ offers the following Warranties

- 20 year return to base Warranty on all MOTECH cell solar PV panels
- 5 year return to base limited Warranty on all Vertex system HDPE collectors
- 1 year return to base limited Warranty on all Vertex system pumps

See our Terms and Conditions page for further details: www.EcoOnline.com.au/terms-and-conditions



Read Carefully

Customer please note: **Collector warranty is VOID** if collectors are installed:

- without a **vacuum release valve** on the inlet line,
- or **in a manner that prevents collector from fully draining** when the pump stops.

Such installations will expose the collectors to strong fatiguing positive/negative pressures, and/or stagnant hot chlorinated water on hot days. These situations will have detrimental effects on the collectors which will limit lifetimes and can also result in significant shrinkage of the collectors which would put strain on roof attachments means.



Read Carefully

Pump **warranty is VOID** if pumps are installed:

- with a pump height greater than 3.5m (per pump for dual pumps)
- or **installed above the waterline** or without the **protective bypass line**,
- or with **inappropriately sloped or non air tight suction line**,
- or with the suction line **tee'd into the mains pump filter line without independent suction ports installed**,
- or **without the Vertex strainer**.

4 System Sizing Guarantee

Sizing systems is difficult involving a lot of factors which we could get wrong. Hence in addition to the above Warranties EcoOnline offers a System Sizing Guarantee as follows. If we sized your system (or you use our online calculator) and you took our advice and you aren't happy with the systems performance (heat output), then you can purchase *up to 25% more* panels originally supplied by EcoOnline **up to two years** after your original purchase and we will ship the items **free of shipping charges**.

5 Collector and Solar Pump Sizing Guide

An interactive collector and pump sizing calculator,

for vinyl **covered spas pools** can be found on our website:

www.econline.com.au/covered-spa-heating-system-sizing-calculator

for **uncovered or blanket covered** pools or swim spas please use the calculator here:

www.econline.com.au/uncovered-swim-spa-heating-system-sizing-calculator

6 Spa Chemistry Compatibility Guide



CAUTION

This system is **not compatible with bromide chlorination, hydrochloric acid use and/or acidic pool/spa water (pH less than 7.2)**. Sodium Carbonate must be added to protect the system from acidic pH (<7). pH should be maintained between 7.2-7.8 for maximum system longevity. If required Sodium Bisulphate acid can be used to keep the pH down.

Incompatible Chemistries	Alternatives Chemistry
X Bromide Based Chlorination	✓ Any other Chlorination or Sanitation
X Hydrochloric Acid	✓ Sodium Bisulphate Acid
X Acidic Water (pH less than 7.2)	✓ Water pH greater than 7.6



Tip

For maximum pump and system longevity we strongly recommend a non-chlorine/bromide based sanitation method.

7 Roof Type Compatibility Guide



WARNING

The average air gap distance between the mounted collector and roof structure has a strong influence on wind loadings. If panels are to be installed on a roof then the following should be observed to limit wind uplift potential.

- 1) **Installed panels should lay flat close to the roof structure.** It is recommend the air gap distance between the bottom of the installed collector and the valley points of the roof corrugations should be no greater than approximately 40mm.
- 2) **Panels should have adequate clearance from roof edges.**
- 3) **Panels on roofs should not be mounted on tilt frames.**

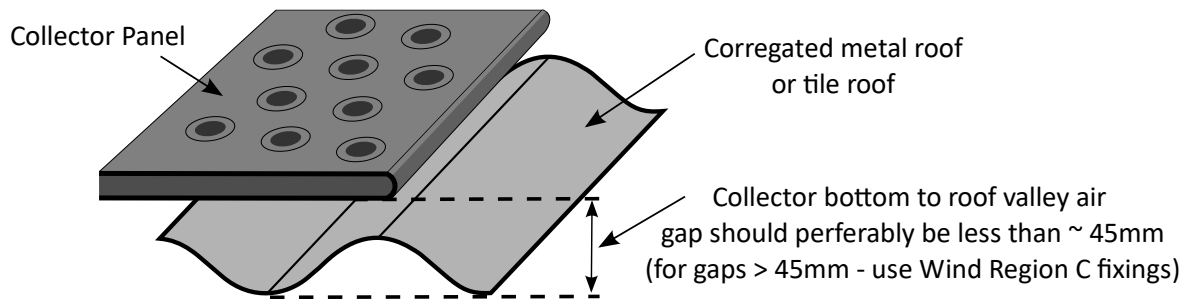

Roof Type	Peak to Valley Measure	Recommendations
Standard Corrugated Iron roof (Custom Orb)	17mm	Use Respective Wind Region Fixings
Relatively Flat Tile roof	Less than 25mm	Use Respective Wind Region Fixings
Spandek Iron roof	24mm	Use Respective Wind Region Fixings
Modulated Tile roof	Greater than 25mm	Use Next Level Wind Region Fixings
Trimdek Iron roof	29mm	Use Next Level Wind Region Fixings
Klip-lok Iron roof	43mm	Use Highest Wind Region C Fixings
Flatdek Iron roof	45mm	Use Highest Wind Region C Fixings



WARNING

Panels installed above the roof structure with 50mm or greater underneath air gaps experience much higher wind loadings and are now subject to the Australian wind loading standard AS/NZD 1170.2.

8 Wind and Climate Considerations





CAUTION

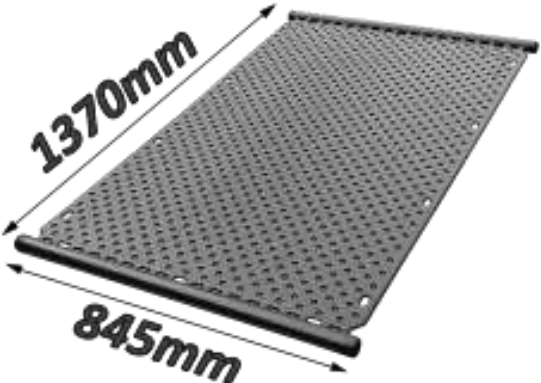

It is the responsibility of the installer to consider wind loading factors, see “wind proofing” section below. **If the installation site is within strong wind speed areas then the extra stainless steel guide line must be installed across each row with the in-between panel anchor points.** Do not assume supplied components are sufficient.

9 Included System Components



Panel Kit (if purchased)

 <p>1 × HDPE collector panel</p>	 <p>2 × 40mm reinforced silicon joiners 4 × Stainless steel hose clamps</p>
 <p>6 × 316 stainless straps (black) 1 × 10cm length perforated 316 stainless band</p>	

12V Solar Pump Kit

	
<p>1 × 20/40/60W 12V Solar pump with electrical connector (max 3.5 pump height)</p>	<p>1 × 40W or 60W Solar panel with PVC wire, connector and under-temperature thermostat</p>

Vertex Base Plumbing Kit Components

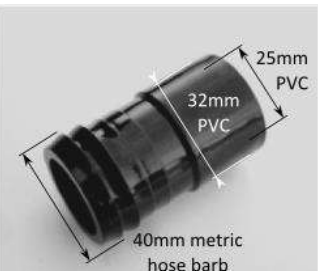
			 <p>25mm PVC 32mm PVC 40mm metric hose barb</p>
<p>1 × Vacuum (and positive pressure) air release valve</p>	<p>1 × Vertex Strainer, flex line outlet & by-pass line kit</p>	<p>1 × PVC non-return and 25mm bubble chamber kit</p>	<p>2 × 40mm hose barb to 25/32mm PVC glue socket/take off</p>

Safety Over-Temperature Thermostat Kit



- 2 × 25mm ID Armaflex pipe insulation
- 1 × 60mm ID Armaflex pipe insulation
- 1 × Aluminium U-channel
- 1 × Twin 40°C thermostats with 2m cord and positive disconnect connector
- 3 × PVC coated stainless cable ties

1 × 5m PVC Extension Wire

Roof Mounting (Solar roof hook supplied only if requested and purchased)

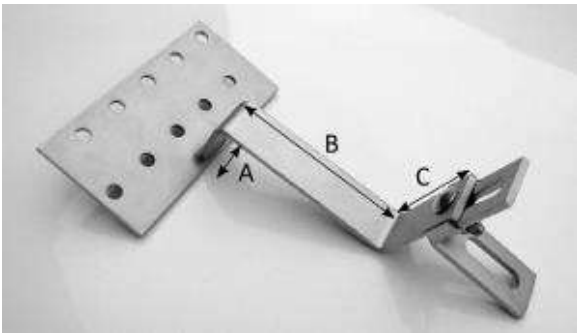

1 × 304 Stainless solar roof hook (height adjustable)

Dimensions: A = 47.5mm, B = 112mm, C = 60mm

10 Additional Required Components (Not Supplied)



10.1 Ground Mounting Support Frame

You may need to build a support frame for your collector array, if so you may require the following:

- Two 70mm x 35mm 1.3m treated pine length per collector (lengths depend on mounting preferences)
- Two 70mm x 35mm 1.1m treated pine length per collector. (Preferably, if transport is available these horizontal lengths should span the collector array or be as long as possible, see section 6.1 below)
- 60mm galvanized timber screws.
- Black outdoor paint (optional)

10.2 Roof Mounting

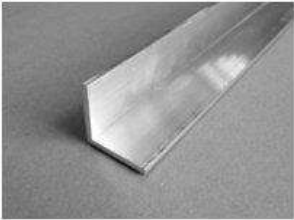



If installing the panels on a roof you will also require the following extra items.

	
32mm x 32mm x 3mm Aluminium angle	4mm stainless steel cable & four cable ties per row

These are available in any plumbing store. The aluminium angle is available from Capral Ltd. or Ullrich Aluminium Pty. Ltd.

10.3 Additional Plumbing Components

You also require some of the following extra items depending on your system. These should be available in any spa/swimming pool supplier.

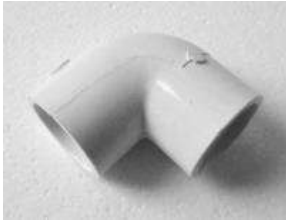
				
PVC 20mm & 25mm piping	Spa suction and return adapters	P-type PVC cement & primer	20mm "Spa flex" flexible PVC hose (note: requires special flex cement)	Other 20mm or 25mm PVC plumbing bits



CAUTION

We recommend **AS 1477 compliant PVC 20mm piping with PN9 pressure rating or greater** and matching PVC fittings be used for all plumbing. We also recommend 20mm "spa flex" flexible PVC hose for suction line pump plumbing for frost prone areas. **(Do not use any irrigation fittings as they are not compatible with chlorinated water).**

11 Required Tools

- Battery powered hand drill with 8mm Hex socket
- Clear silicon
- PVC glue (Green pressure)
- Soldering iron
- Screwdriver with 8mm socket fitting
- Hack saw (metal blade to reduce PVC filing size)
- Level
- 3mm drill bit

12 Safety When Working at Heights



DANGER

WHEN WORKING AT HEIGHTS - SAFETY COMES FIRST. A person can easily fall off a ladder or roof and be seriously injured. For installations on a roof pitch greater than 22° and/or a double story house we strongly recommend a highly competent professional installer install your solar collector array. The installer **MUST** use an appropriate safety harness.

The installer should always take the necessary safety precautions:

- Choose an appropriate day: cool, dry, calm and partly cloudy.
- Plan out your install: make sure you have all required components, tools and have plenty of allocated time.
- Only work at heights when you are well rested and alert.
- Never work alone, always work with at least one other person.
- Always use a safety harness or fall arrest system attached to appropriate roof anchor points.
- Wear clothes that fit well but that do not restrict movement.
- Use proper non-slip shoes.
- Use sunscreen.

12.1 Ladder Safety

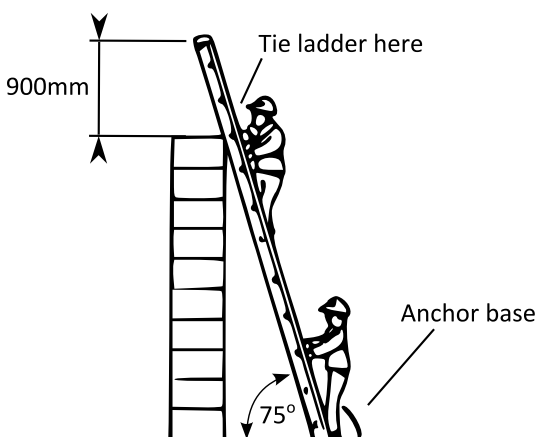

The chance of a falling from a ladder should never be underestimated. Use only solid **industrial grade** ladders in good repair that have been checked for faults.

Note: even a small unexpected movement of the ladder, such as a small slip, can cause loss of balance and result in a fall.

The ladder should be placed on solid ground and should **ALWAYS** be securely anchored at the base and secured at the top to prevent slipping.



DANGER

Solar panels should not be mounted in windy or gusty conditions; a panel can easily be caught in the wind and cause a loss of balance and result in a fall.

13 Choosing A Place to Install the Collector Array

When choosing a location for your collector array you should consider the following in order of importance:

1. **Shading** - the collectors should receive no shading between the hours 10am to 4pm.
2. **Wind** - the collector array should be mounted in a relatively sheltered location or with appropriate wind proofing.
3. **Direction** - collectors should face **NNW for maximum heat collection**, however acceptable directions face between NE to W only. Systems facing other directions will have significantly impaired performance.
4. **Distant to pool/spa** - collectors should be as close as possible to your spa (or pool), or have insulated lines.
5. **Mounting elevation** - flatter elevations (< 45°) collect more heat in the summer while installations closer to vertical (> 45°) produce more heat during spring/autumn.



DANGER

For ground mounted arrays, under no circumstances should a collector array be mounted in anyway so as to compromise the effectiveness of a pool or spa Child Safety Barrier.

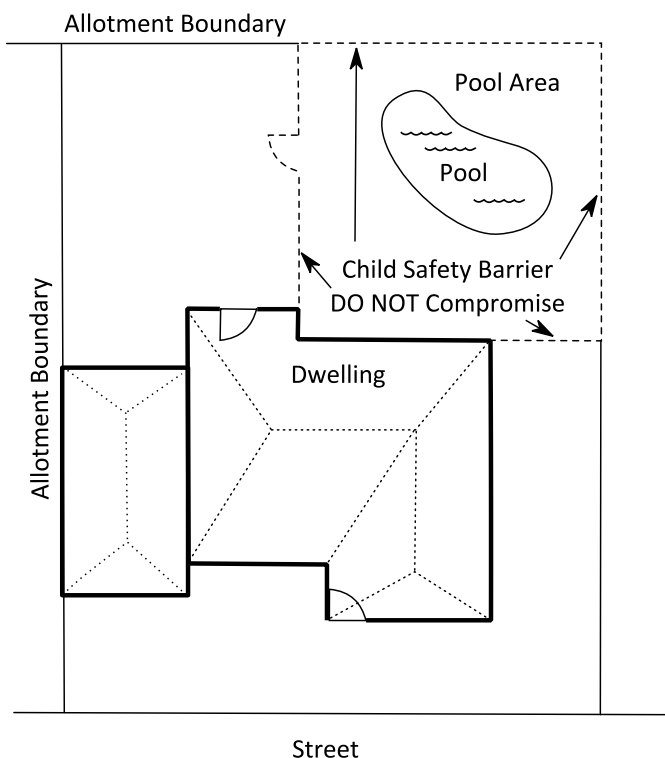

The figure to the left shows an example of a Child Safety Barrier marked with a dashed line. A collector array should not be mounted near the Child Safety Barrier - **both on the inside and outside of the Pool Area** unless proper clearances are observed. **Consult your Local Government, The Building Commission or SPASA for details regarding pool safety barriers in your state.** Please keep up to date with regulations as they change over time. For more information see, AUSTRALIAN STANDARDS 1926.1 2007 AND 1926.2 2007 FOR POOL SAFETY BARRIERS.

- Do not install the collectors **leaning against the outside of a Child Safety Barrier** so as to create a climbable object for children to access the pool or spa.
- Collectors installed inside the pool area in front of a boundary fence must be offset away from the boundary fence with the **proper clearance** from the top of the fence so as not to provide a foothold for a child climbing into the pool area.
- Do not install the collectors too close to the inside of a Child Safety Barrier so as to provide **foot or handholds from the outside** of the barrier.
- For spa pools and above ground pools do not lean the collector array against the side of the spa or pool so as to create a **ramp or climbable object**.

14 Pump and Solar PV Panel Test



CAUTION

During the following test **DO NOT** allow the pump to run completely dry as this will damage the pump.

- 1) On a minimum 18°C sunny day, place the solar panel in full sun and wait 15 minutes for the panels under temperature thermostat mounted inside the junction box to warm up to 40°C. If required warm with a hair dryer.
- 2) Place the pump inside a bucket of water (the pump is submersible).
- 3) Connect the solar PV panel; the pump should start in 3-4 secs.

14.1 What if the Pump Won't Start?



- 1) Check that there is sufficient sun and that **no cell of the panel is shaded**.
- 2) Check that the under-temperature thermostat is ON and that the panel is producing power (if a multimeter is not available, insert an old 50W halogen globe into the panels electrical connect – **do not do this in full sun, angle panel to sun to reduce power**).
- 3) Check that the wires in the connector aren't twisted internally and the positive and negative connections line up.
- 4) If it still won't start please contact us at info@EcoOnline.com.au for technical support.

15 Collector Array Configurations

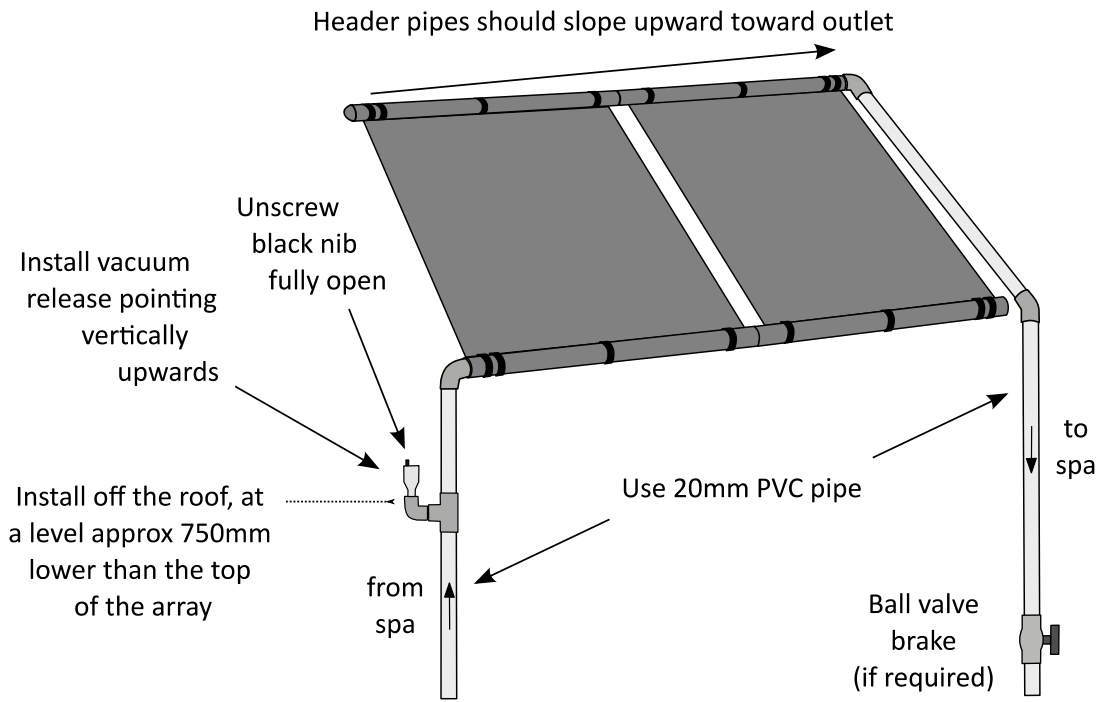

Read Carefully

To make sure all air bubbles are evacuated upon filling, collectors **MUST** be installed with a minimum recommended pitch of 5°. Also ideally the top header pipe should have a 1 or 2° upward slope toward the top outlet return, such that the top outlet return corner of the collector array at the highest point.

15.1 Array Configurations Not Recommend

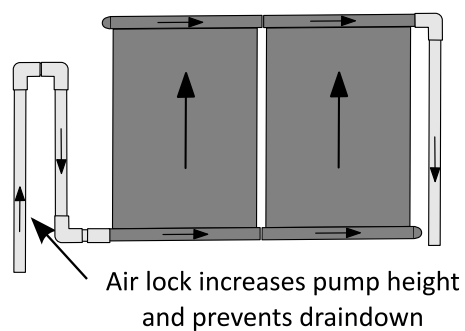
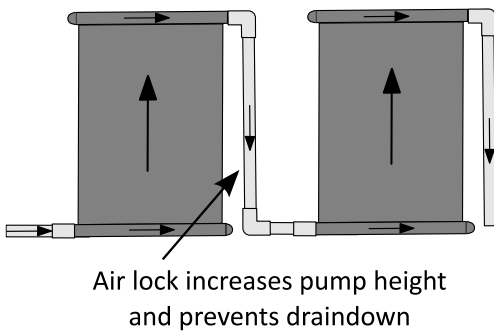
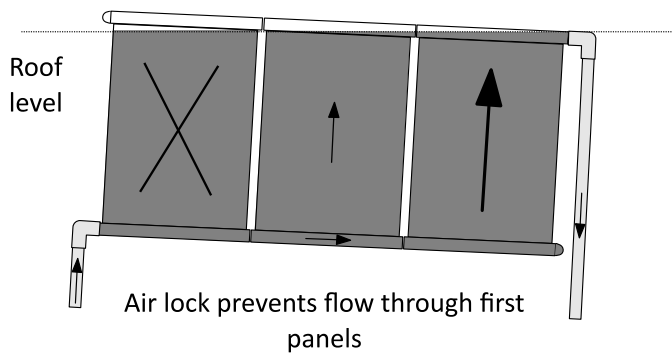
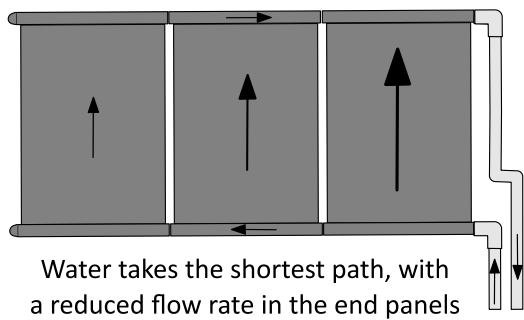

16 Roof Attachment Options



CAUTION

Note the high thermal contraction and natural relaxation of HDPE: Collectors will contract (in length) by up to 10mm over time and 12mm thermally across temperature extremes. **Hence any fixing means must account for an ultimate contraction of 22mm in length per panel.**



CAUTION

Key design principles when choosing a roof mounting means:

- 1) Consider the high thermal contraction of HDPE
- 2) Panels should be as low down on the roof as possible to prevent the wind from catching the underside of panels
- 3) The stainless steel straps must allow for thermal movement of panels.

16.1 Tile Roof Mounting Frame



CAUTION

For tile roofs we recommend using a minimum roof hook spacing of 600mm in the top and bottom row. Depending on your wind loading (see “Wind Proofing” section), angle of install and the dead weight of the collectors, you may require a higher density of roof hooks and/or a stronger Aluminium L-angle, if unsure please seek advice.

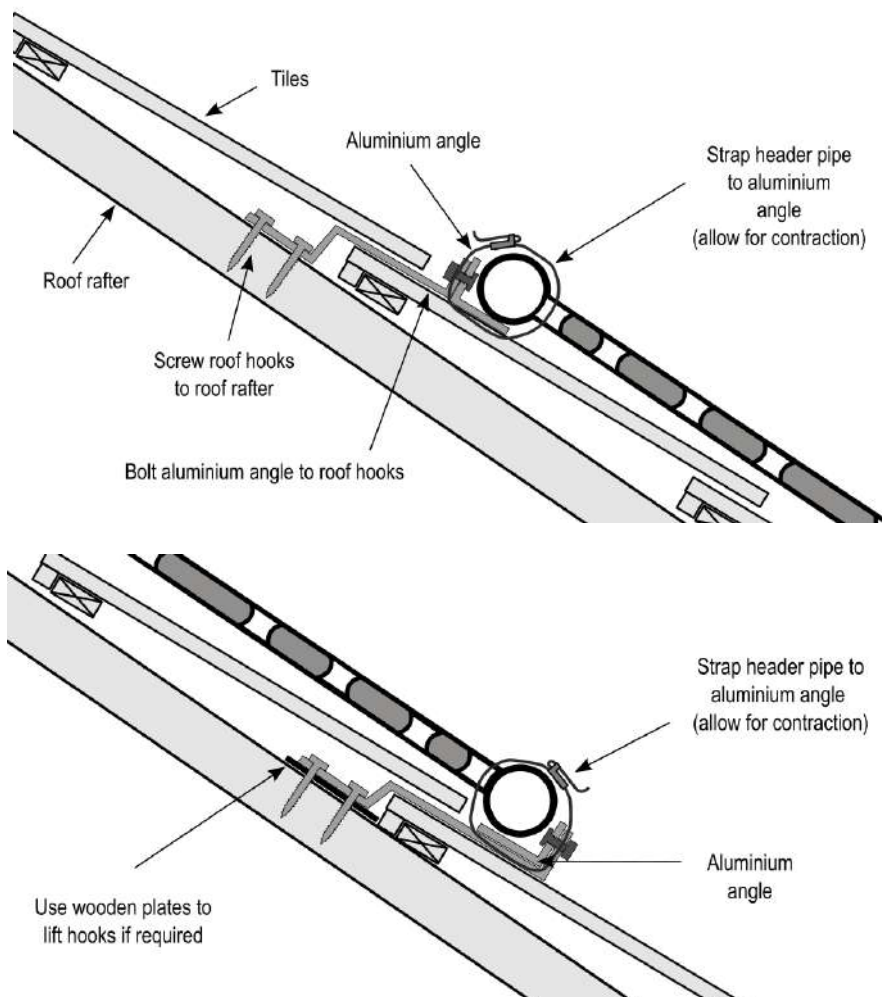

17 Corrugated Metal Roof Aluminium Angle Mounting Options



WARNING

For metal roofs we recommend using a minimum screw fixing space of 600mm when fixing the aluminium angle. Depending on your wind loading (see “Wind Proofing” section), angle of install, you may require a higher density of fixings and/or a stronger Aluminium angle, if unsure please seek advice.

17.1 Aluminium Angle Mounting Options

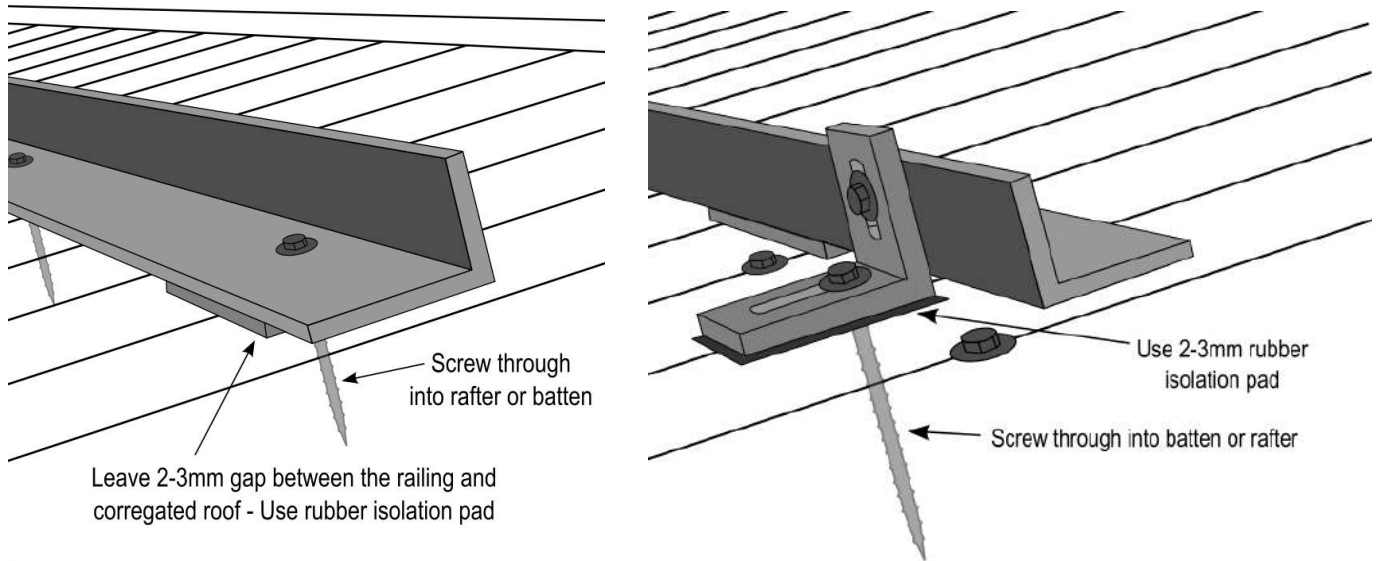

17.2 Thermal Expansion Gaps for Aluminium Channels

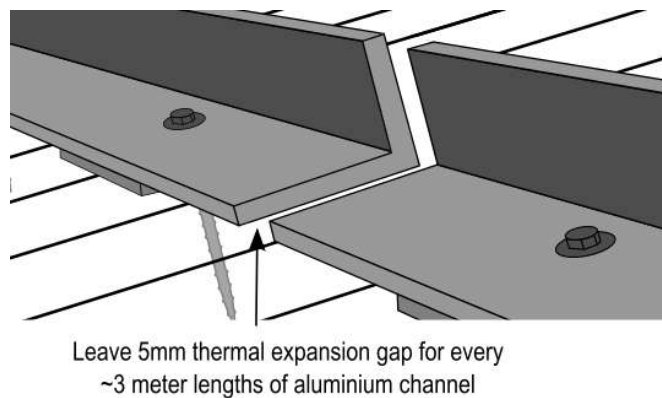

17.3 Metal Roof Screw Selection and Method

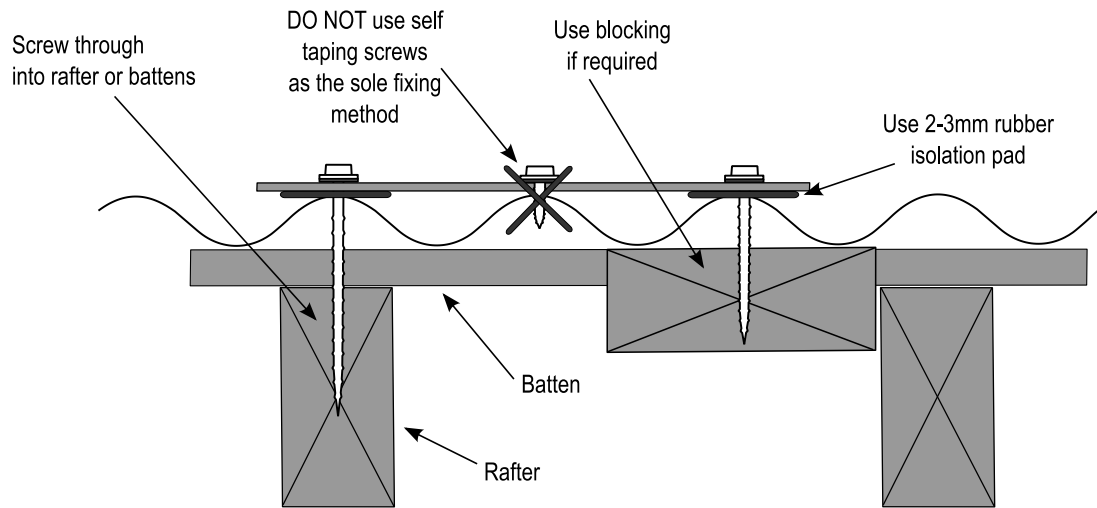

18 Collector Mounting Procedure

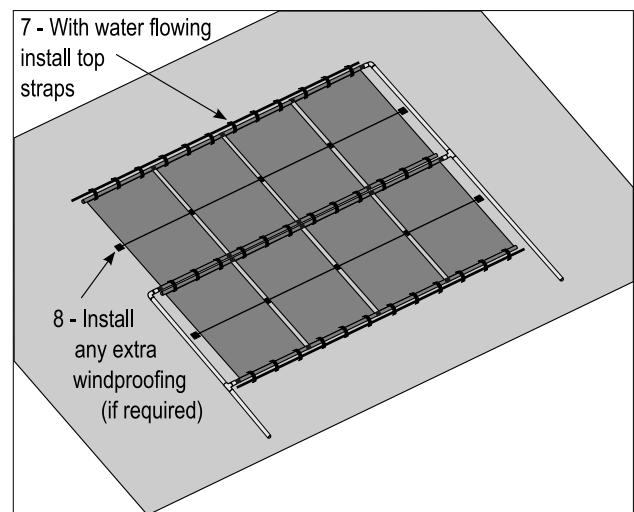
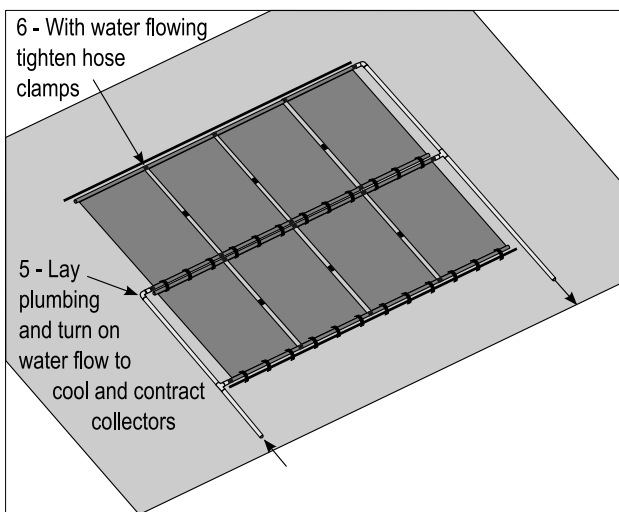
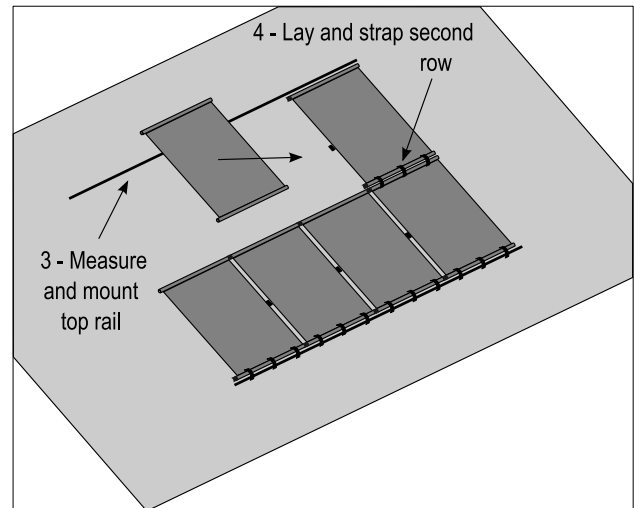
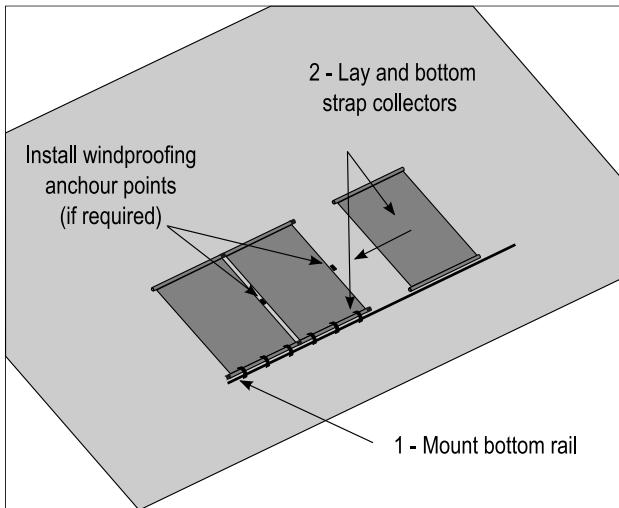

CAUTION

Collectors will contract (in length) by up to 10mm over time and 12mm thermally for an ultimate contraction of 22mm in length per panel. For a two row array strapped between a top and bottom aluminium rail the total ultimate contraction is then 44mm. The top and bottom strap must have sufficient play to account for this ultimate contraction.



CAUTION

It is strongly recommended that the top straps be applied while cool pool/spa water is flowing through the panels.



WARNING

The collectors can be walked on without damage. For tile roofs with solar roof hook care should be taken not to step on or near a roof hook as you may crack a tile. Take extreme care to use non-slip shoes and never walk on wet collectors. **HDPE material is slippery and waxy. If the collectors need to be walked on for mounting purposes, ALWAYS use a safety harness and fall arrest system.**

19 Collector Array Plumbing Connections

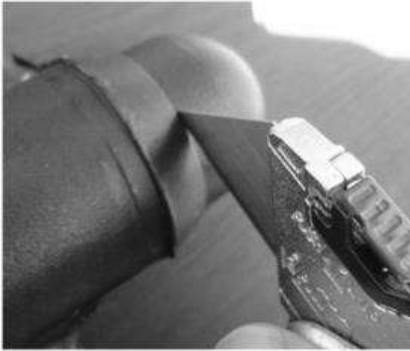

BEFORE CUTTING - put aside two collectors per row with **undamaged end caps**. For all remaining collectors cut the single end cap off using a sharp blade.



WARNING

Laceration hazard: Always cut away from your body and ensure no parts of the body are in front of the cutting blade. Plastic can be softened by heating.



Check all collector pipe connections for raised edges or grooves on the weld lines which could channel water and cause leaks. Shave any edges or grooves flat with a blade being careful not to cut into the pipe.



Insert silicon joiners and moderately tighten the hose clamps using with an 8mm hex socket. **Do not glue in silicon joiners**. If there is a pin hole leak, a small amount of silicon can be used to seal. Note: You'll need to re-tighten these with cool water running through the collectors at a later stage, as HDPE has a high thermal contraction.



The **barb end** of inlet/outlet PVC adapter should be glued into the 40mm silicon joiner with any neutral cure silicon. A flat spatula type surface should be used to push silicon into the barbs indentations (as shown).

***Why?** PVC barbs can soften at extreme roof stagnation temperatures and contract slightly with clamp pressure. HDPE on the other hand will not soften significantly at the maximum roof stagnation temperature of ~80°C.*

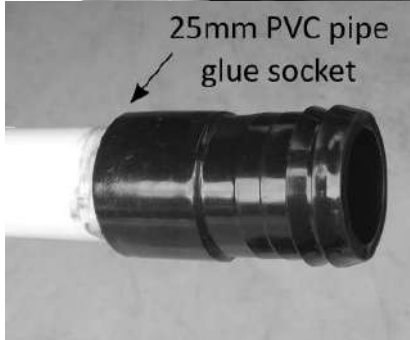

The **non-barb end** of inlet/outlet PVC adapter should be glued into 25mm PVC piping.

20 Roof Fixings



WARNING

When working with power or hand tools always follow the safety instructions.

- Wear the recommended personal protective equipment, such as **gloves, safety glasses, respiratory and hearing protection.**
- Make sure electrical cables are kept away from any water and from foreign objects which pose a **potential cable severing or crushing hazard.**
- When using glues, solvents or sealing agents make sure **you know and seek the proper first aid** in case of an accident.

20.1 Application of the PVC Coated Stainless Steel Straps

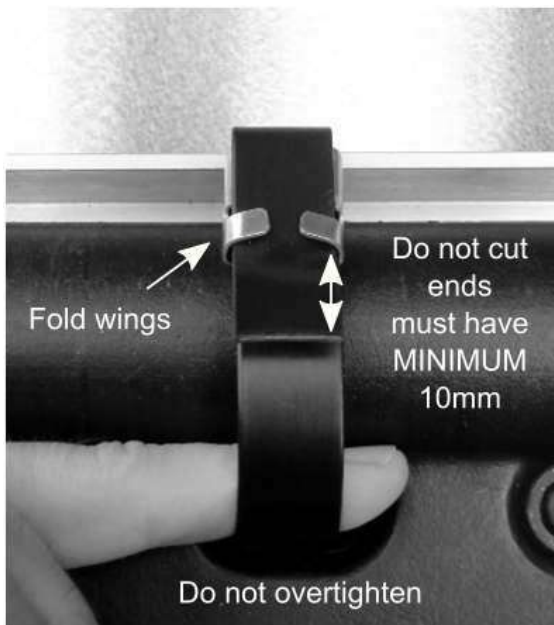
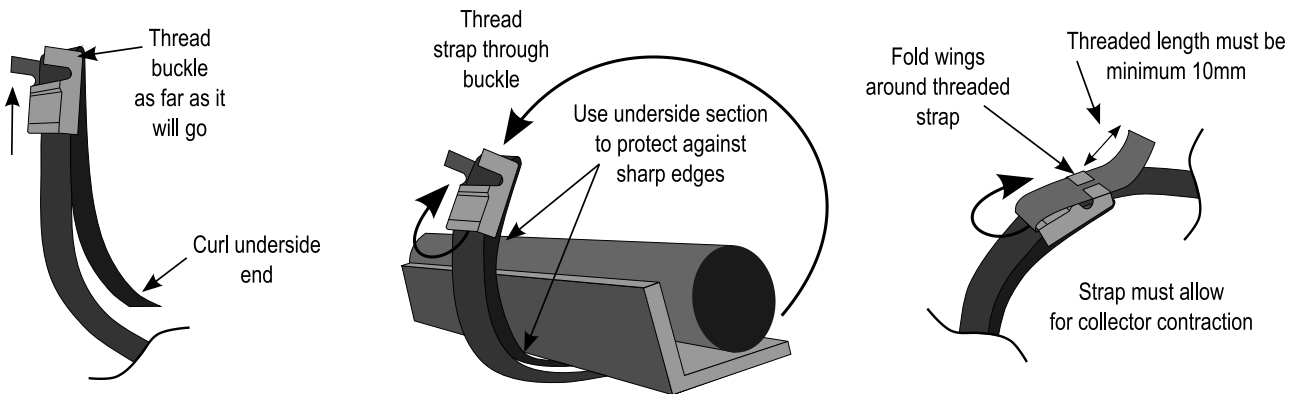

WARNING

IMPORTANT: DO NOT over tighten stainless steel strapping. **Strapping must have sufficient play to allow for collector contraction.** For the installation of two rows between two aluminium channels top and bottom strapping should be loose enough to insert your **little finger** between the strapping and the header pipe. *Why? Overtightened straps can experience tension and continual flexing of the metal due to the thermal contraction of the collectors. This can result in metal fatigue of roof fixings over time.*

20.2 Single or Multi-Row Metal Roof Fixings Wind Region A

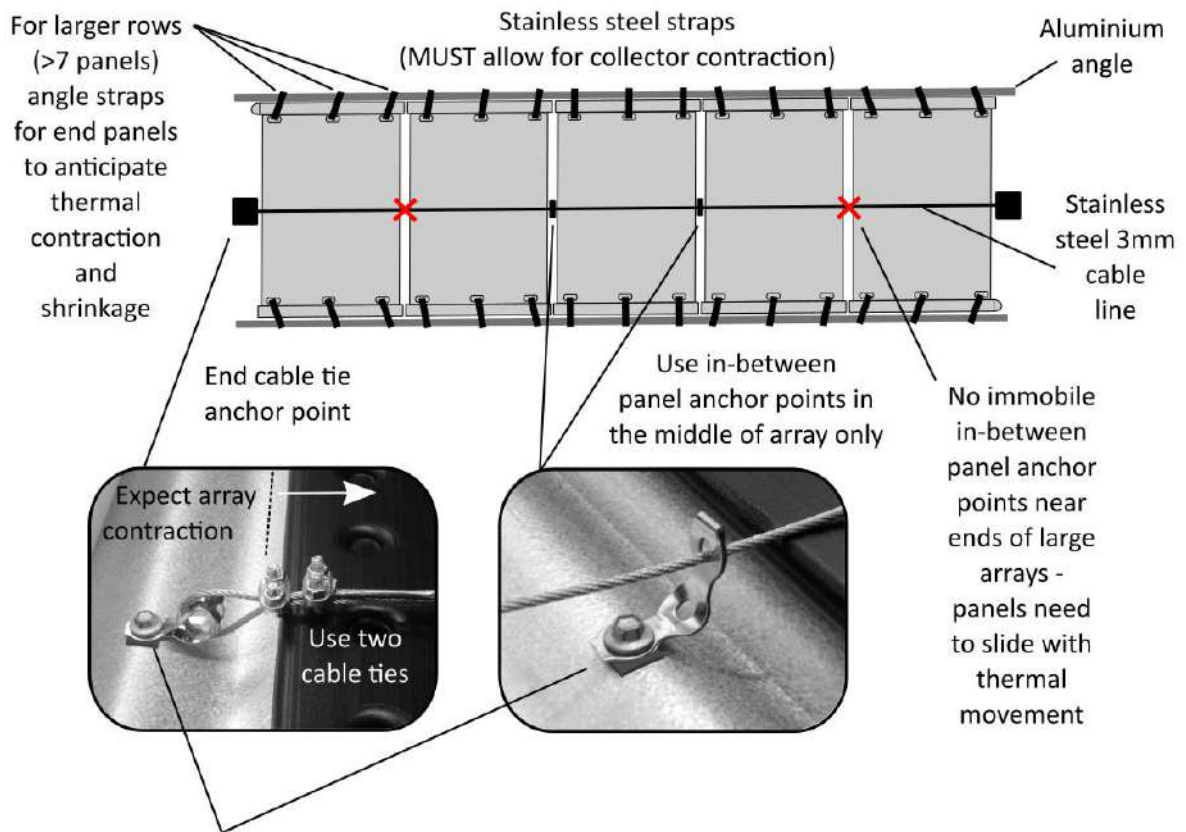

All roofing screws must be sunk 50mm into batten, rafter or wooden back blocking
Use rubber isolation pad (No self-tapping screws or pop-rivets allowed)

20.3 Single or Multi-Row Metal Roof Fixings for Wind Regions B & C

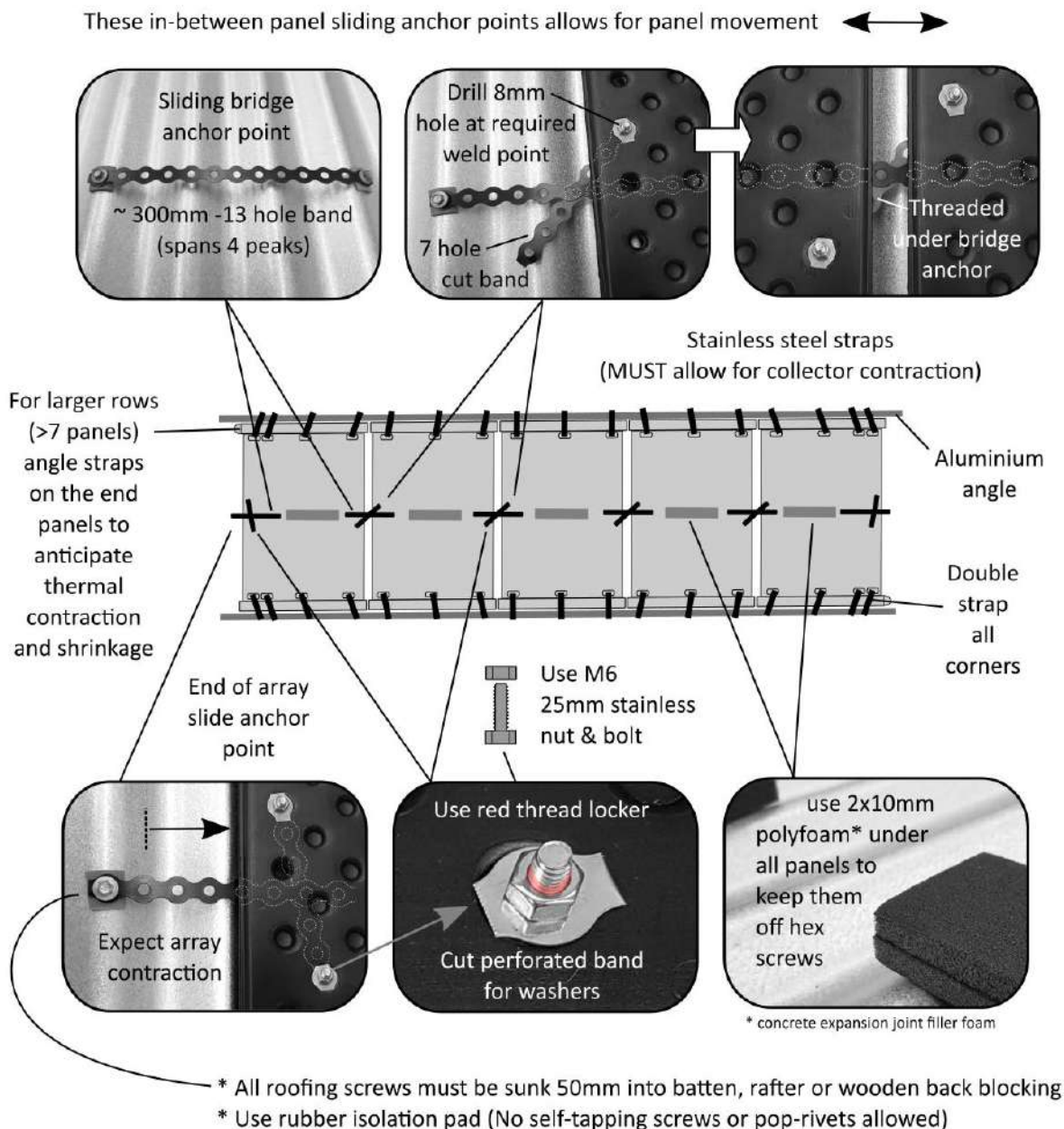

WARNING

NOTE: For single or multi-row arrays in wind regions B or C, aluminium L-angle MUST be run for the top and bottom of each row.

20.4 Single or Multi-Row Tile Roof Fixings for Wind Region A & B

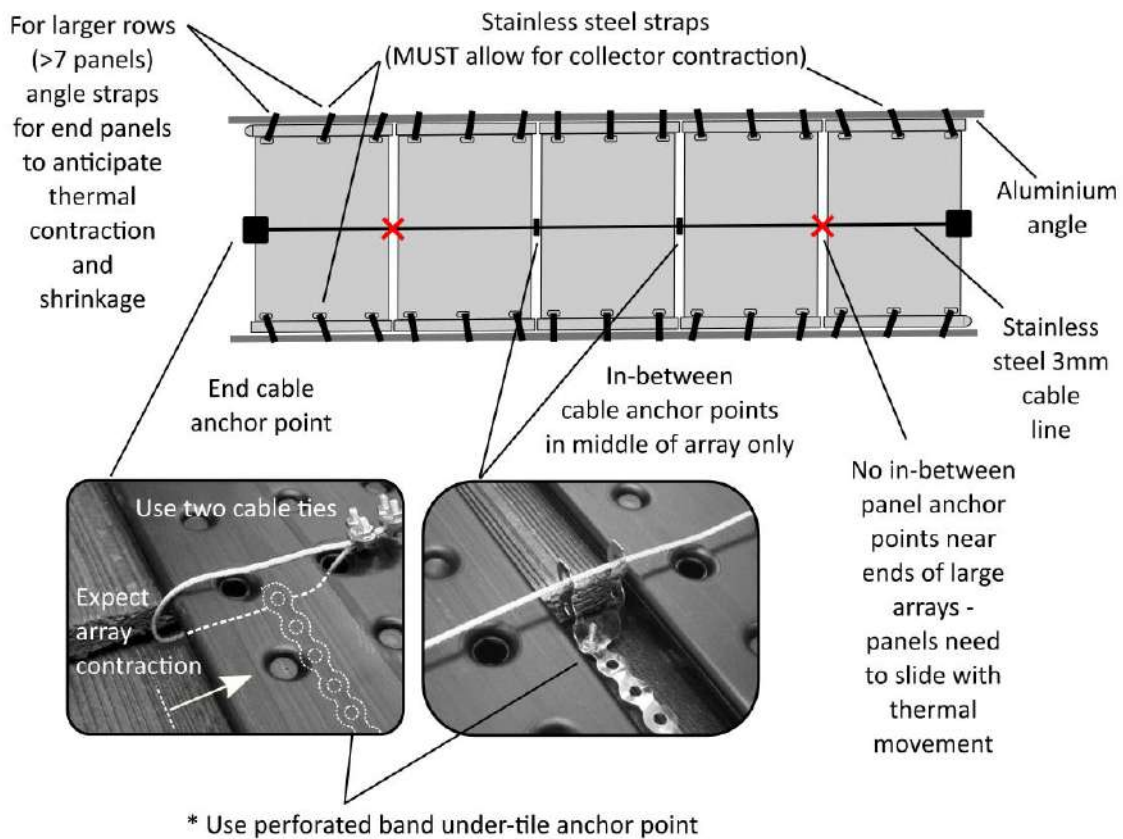

WARNING

For single or multi-row arrays in wind regions B, aluminium L-angle MUST be run for the top and bottom of each row.

20.5 Perforated Band Under-Tile Anchor Point (For Region B or Two row arrays)

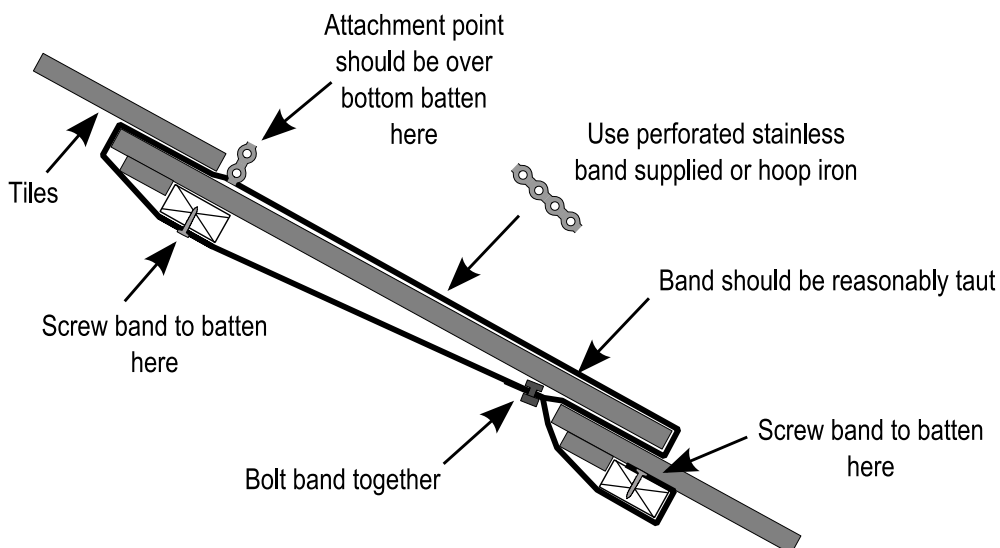

21 Wind Proofing

Note, roof installation of these panels in Wind Region D is not recommended. This section provides general advice on wind loadings. If you have any doubt about your wind loadings please contact info@EcoOnline.com.au

21.1 Ultimate Peak Wind Loadings per Panel

The following Tables specify the ultimate peak uplift any single panel can experience in a 1 in 500 year extreme storm or cyclone event according to Australian Standard 1170.2 - 2011 (Amend 2 Dec 2012). These tables assume:

- 1) Panels are mounted on (touching) the roof structure - or no more that 20mm off the roof surface
- 2) Panels are situated away from a roof edge or corner
- 3) Installation is on a first story roof
- 4) Shortest side length of the building is more than twice the average building height (i.e. flat building)

If your installation falls outside of these assumptions please contact info@EcoOnline.com.au for alternative loadings.

Ultimate Peak Uplift Loadings Per Panel in Wind Region A (Kg)					
Region A	< 10° Roof Pitch	12.5° Roof Pitch	15° Roof Pitch	17.5° Roof Pitch	> 20° Roof Pitch
Terrain Category 1	120 Kg	110 Kg	95 Kg	90 Kg	80 Kg
Terrain Category 2	100 Kg	90 Kg	80 Kg	70 Kg	65 Kg
Terrain Category 2.5	90 Kg	80 Kg	70 Kg	65 Kg	60 Kg
Terrain Category 3	85 Kg	75 Kg	65 Kg	60 Kg	55 Kg

Ultimate Peak Uplift Loadings Per Panel in Wind Region B (Kg)					
Region B	< 10° Roof Pitch	12.5° Roof Pitch	15° Roof Pitch	17.5° Roof Pitch	> 20° Roof Pitch
Terrain Category 1	195 Kg	175 Kg	150 Kg	140 Kg	130 Kg
Terrain Category 2	160 Kg	145 Kg	125 Kg	115 Kg	105 Kg
Terrain Category 2.5	150 Kg	130 Kg	115 Kg	105 Kg	100 Kg
Terrain Category 3	135 Kg	120 Kg	105 Kg	95 Kg	90 Kg

Ultimate Peak Uplift Loadings Per Panel in Wind Region C (Kg)					
Region C	< 10° Roof Pitch	12.5° Roof Pitch	15° Roof Pitch	17.5° Roof Pitch	> 20° Roof Pitch
Terrain Category 1	290 Kg	255 Kg	225 Kg	210 Kg	190 Kg
Terrain Category 2	240 Kg	215 Kg	185 Kg	170 Kg	160 Kg
Terrain Category 2.5	220 Kg	195 Kg	170 Kg	155 Kg	145 Kg
Terrain Category 3	200 Kg	175 Kg	155 Kg	145 Kg	130 Kg

As an example if you are in **Wind Region B** and **Terrain Category 3** and have a **roof pitch 12.5°** then any single panel in your collector system could experience momentary peak uplifts of **~120Kg** per panel. You should make sure your

panels and fixing components can withstand your relevant loadings. See below for Terrain Category and Wind Region definitions.



WARNING

Note: Installations involving a second story roof or higher, or houses on hills, or panels mounted 50mm or greater above the roof structure have higher potential wind loadings. Please contact info@EcoOnline.com.au for ultimate wind loadings based on your details.

21.2 Frequency of Extra Fixings for Different Regions

For ultimate wind loadings (see Tables above):	Extra Fixings Required
Less than 70Kg per panel	Stainless guide line is not required (but still recommended)
Greater than 70Kg per panel	Stainless guide line is required across each row
Greater than 120kg per panel	Stainless guide line is required with in between anchor points

21.3 Wind Region Definitions

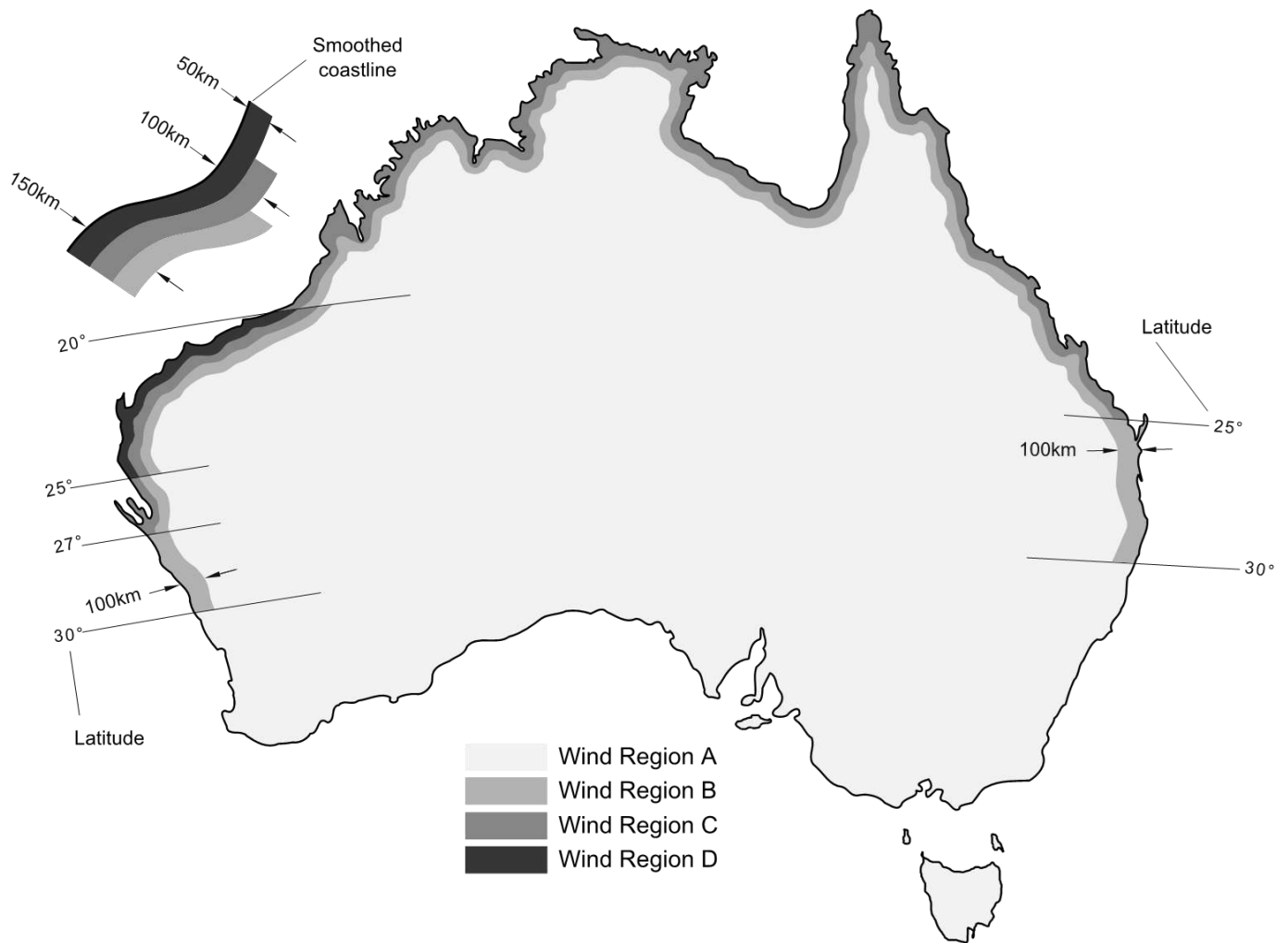

Coastal region boundaries are smooth lines set in from a smoothed coastline by 50km, 100km or 150km lines.

21.4 Terrain Category Definitions

- **Terrain Category 1:** Open terrain few obstructions. Example flat, treeless, poorly grassed plains.
- **Terrain Category 2:** Open terrain with scattered obstructions having heights from 1 .5m to 5m, with at least two building type obstructions per hectare. Example farmland and cleared subdivisions with isolated trees.
- **Terrain Category 2.5:** Averaged intermediate between Terrain Category 2 and Terrain Category 3
- **Terrain Category 3:** Numerous closely spaced building obstructions having heights from 3m to 10m with at least 10 house-size obstructions per hectare. Example fully developed suburb or light industrial estates.

21.5 Roof Edge Exclusions Zones

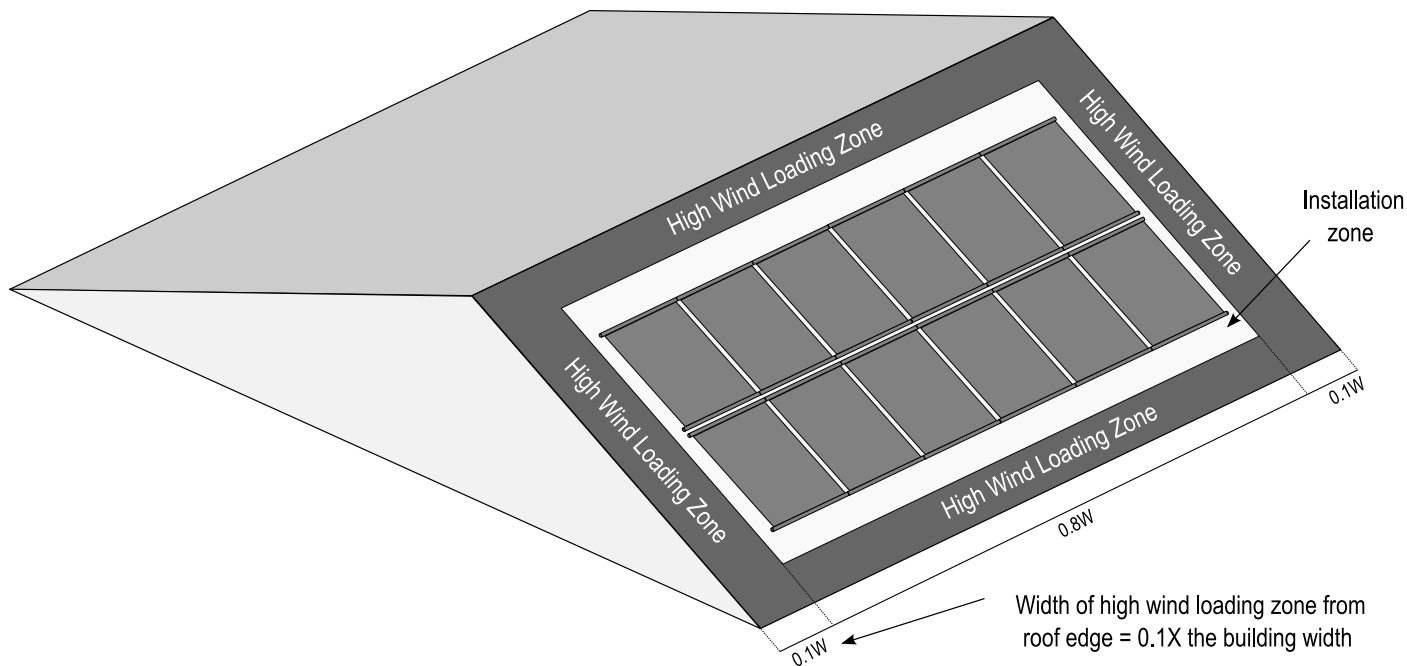

WARNING

Note: Collector installations within a roof edge high wind loading zone will require **2 X** the fixing strength in that local area. Collector installations within a roof corner high wind loading zone will require **3 X** the fixing strength in that local area.

22 Plumbing Diagram

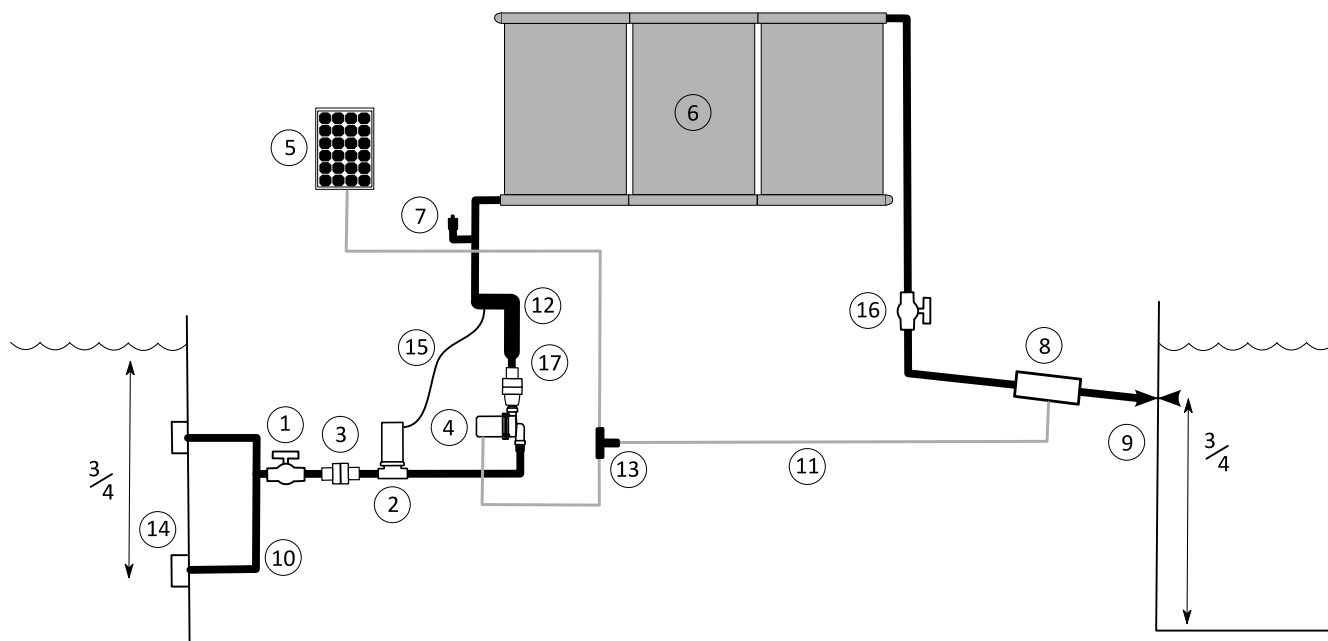

- | | | |
|-----------------------------------|----------------------------------|-------------------------------|
| 1 - Ball valve | 7 - Vacuum release valve | 13 - Electrical tee connector |
| 2 - In-line strainer | 8 - 40C Safety thermostat cutout | 14 - Grated suction inlets |
| 3 - 25mm Barrel union join | 9 - Return line inlet adapter | 15 - Protective bypass line |
| 4 - Solar pump | 10 - Plumbing pipe (Black) | 16 - Back pressure ball valve |
| 5 - Solar electric PV panel | 11 - Electrical wire (Grey) | 17 - Non-return valve |
| 6 - Solar thermal collector array | 12 - 25mm PVC bubble chamber | |



WARNING

The installation of **at least two** Australian Standard approved suction outlet adapters, 600mm apart connected by a T-piece PVC plumbing is **mandated** for pools and spas.



WARNING

Due to the potential for hot water at the outlet on start-up, solar heating outlets shall not be connected to water features or waterfalls, or any other outlet(s) that are not permanently fixed underwater.



CAUTION

We strongly recommend a metal hack saw when cutting PVC pipe to reduce shaving size as the pump has a very fine rotor clearance.



Read Carefully

The Vertex System requires the installation of an independent suction line; **Teeing into the mains pump filter circuit is not allowed.**

23 Suction Line / Pump / By-Pass Line / Bubble Chamber Configuration



CAUTION

The below suction/pump/by-pass line/bubble chamber mounting configuration **MUST be followed exactly**. Take particular note of the **pump and strainer water level and orientation**, the slope in the suction line and the position of by-pass line under the 25mm PVC pipe.

Why? If air traps are present, air bubbles will accumulate in the system when the system drains down through the suction line. Air in the suction line can lock the pump. The below configuration is nearly impervious to air-locks and will prevent the pump from overheating by allowing cooling water flow via the by-pass in the event of a major air lock.

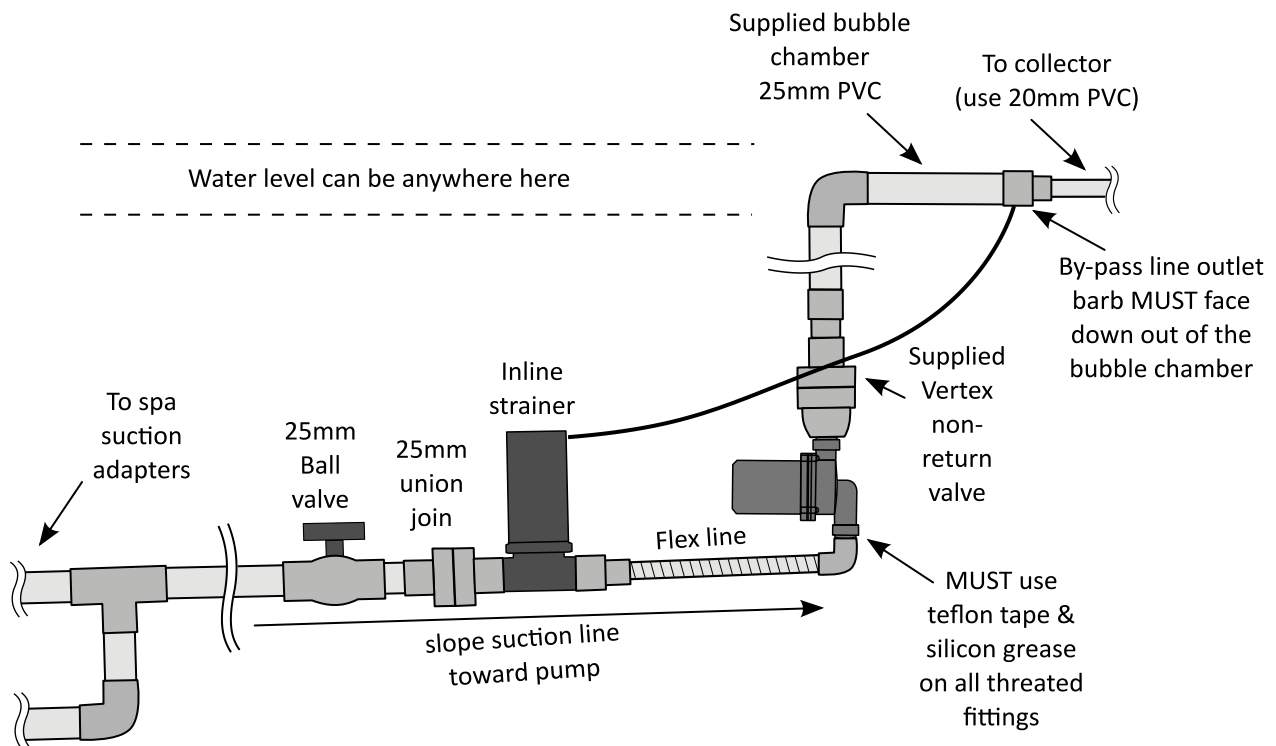

23.1 Installation of the By-Pass Ports and Line

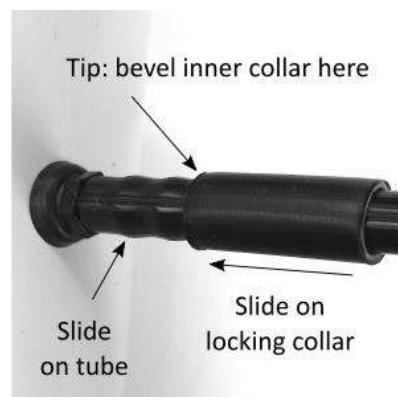
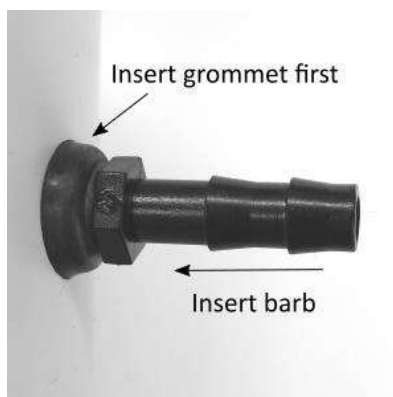

Cut the by-pass line to length so that **there are no loops in the by-pass line (sagging is okay)** and connect to the 6mm barbs on the strainer and bubble chamber as shown. Silicon lubricant can be used on the by-pass tube and

locking collar ONLY – DO NOT use silicon lube on any part of the grommet - water lubricant only.



Read Carefully

The by-pass line comes with a 3mm inner constriction encased in a clear PVC line. This may need cleaning at some point. **Warm the PVC around the barb with hot water and twist, for easier removal from the barb**

23.2 Suction Plumbing Configurations Not Allowed

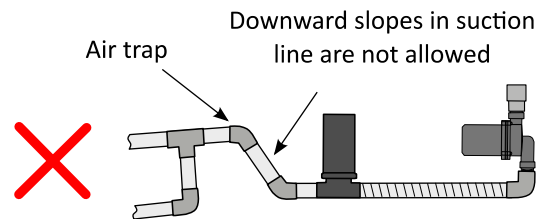
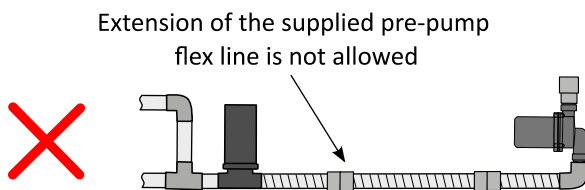
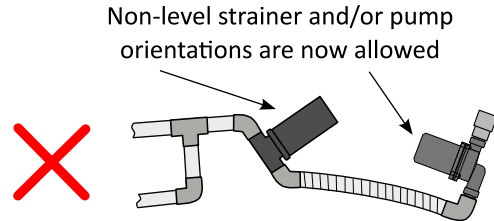
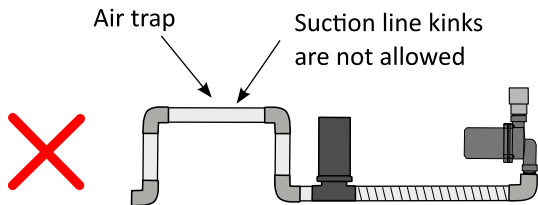

CAUTION

The guiding principle here is that all suction lines must **automatically, fully and completely** flood prime, evacuating all air. **It is not sufficient to clear an air trap in the system by forcing water through. Air can be reintroduced when the system drains down through the pump.** No air traps in lines are allowed, except for the inverted strainer which automatically self purges air via the installed by-pass line.

24 Different Plumbing Situations

24.1 From Spa to Roof Collector Plumbing Setup

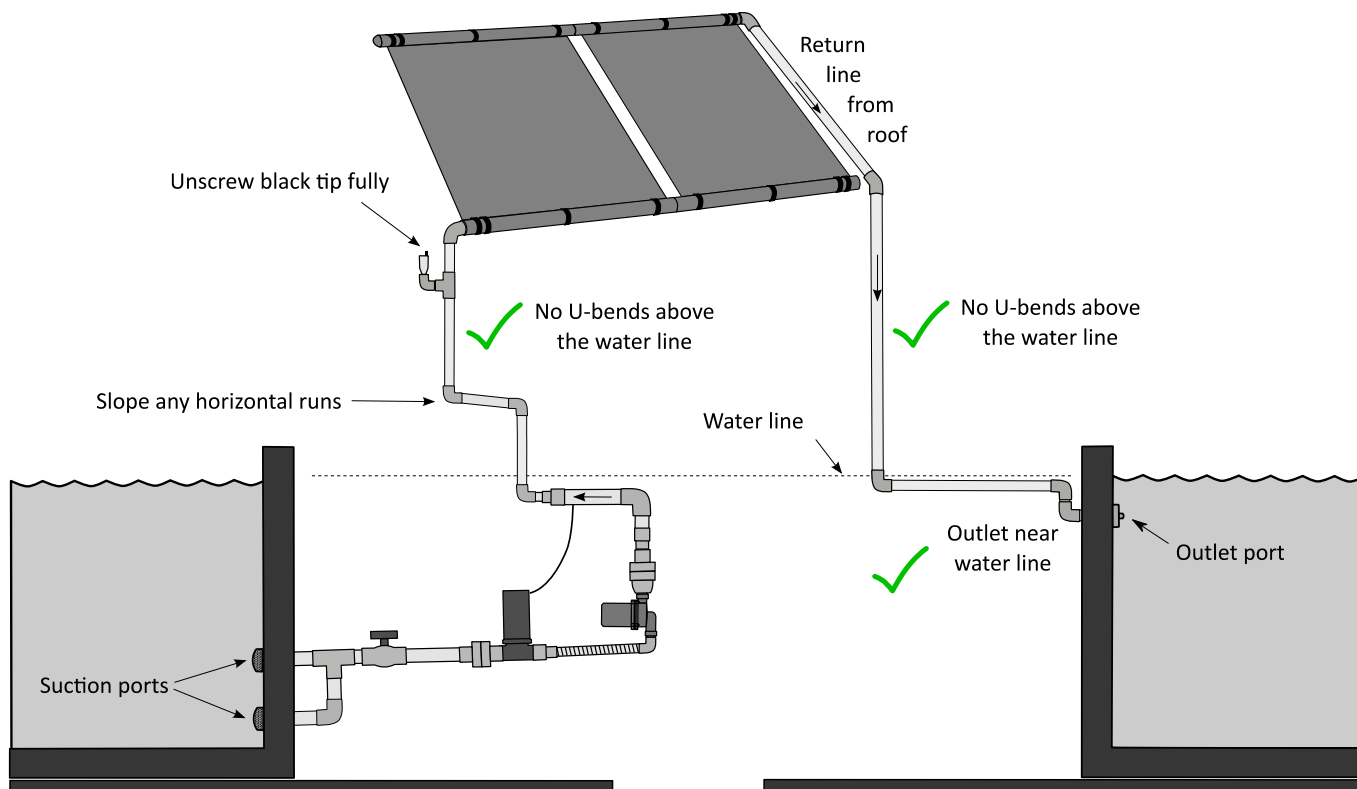

Read Carefully

The Vacuum Breaker valve should face **vertically upward** and be mounted just off the roof on the vertical supply line. Unscrew the top black air intake nozzle.

24.2 From Spa to Ground Run to Roof Collector Plumbing Setup (Extra Vac Valve Required)

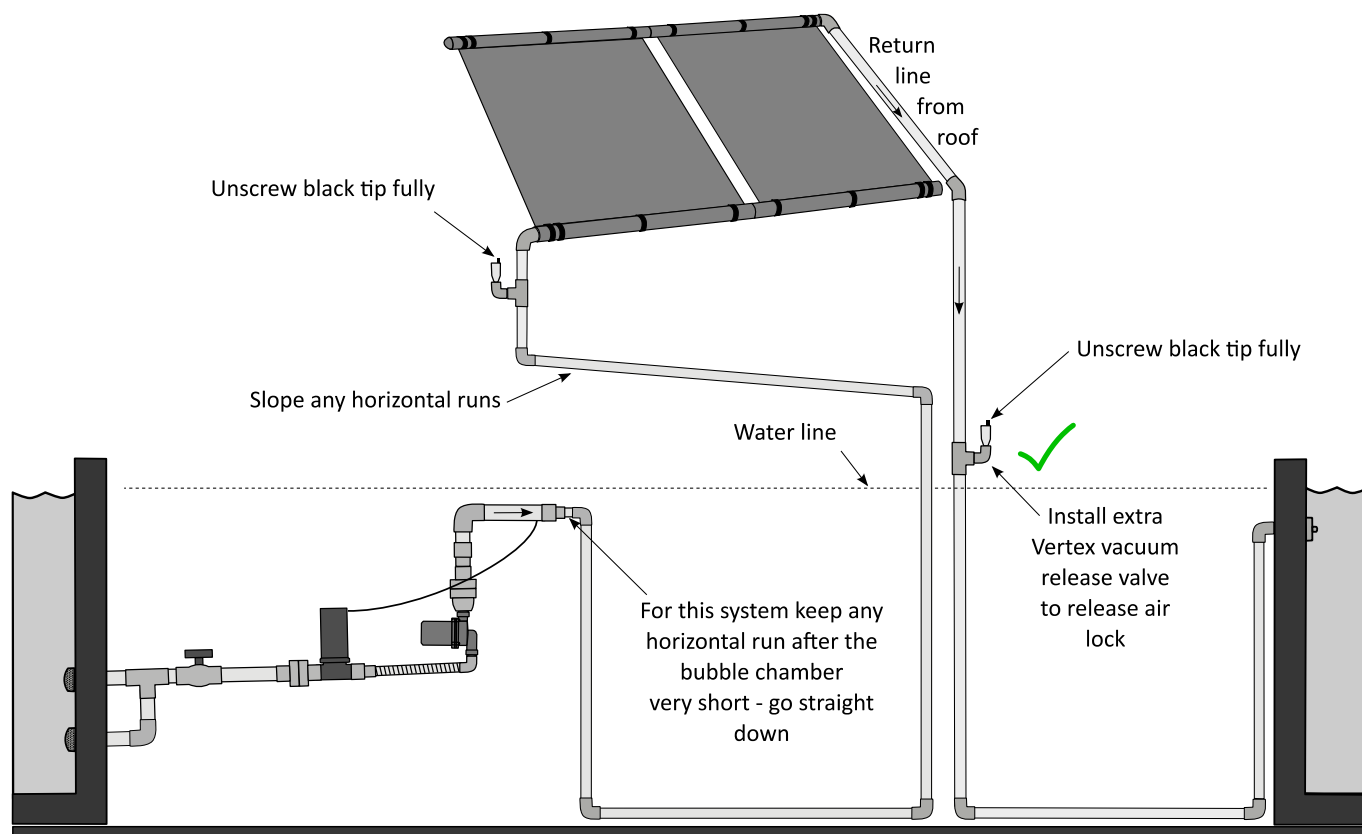

Read Carefully

The Vacuum Breaker valve should face **vertically upward** and be mounted just off the roof on the vertical supply line. Unscrew the top black air intake nozzle.



Read Carefully

If any part of the return line plumbing or return outlet port is installed far below the water line (greater than 0.5meters) then an extra Vertex vacuum beaker valve should be installed on the return line to remove the extra pump height created.

24.3 From Spa to Ground Mounted Collector Plumbing Setup

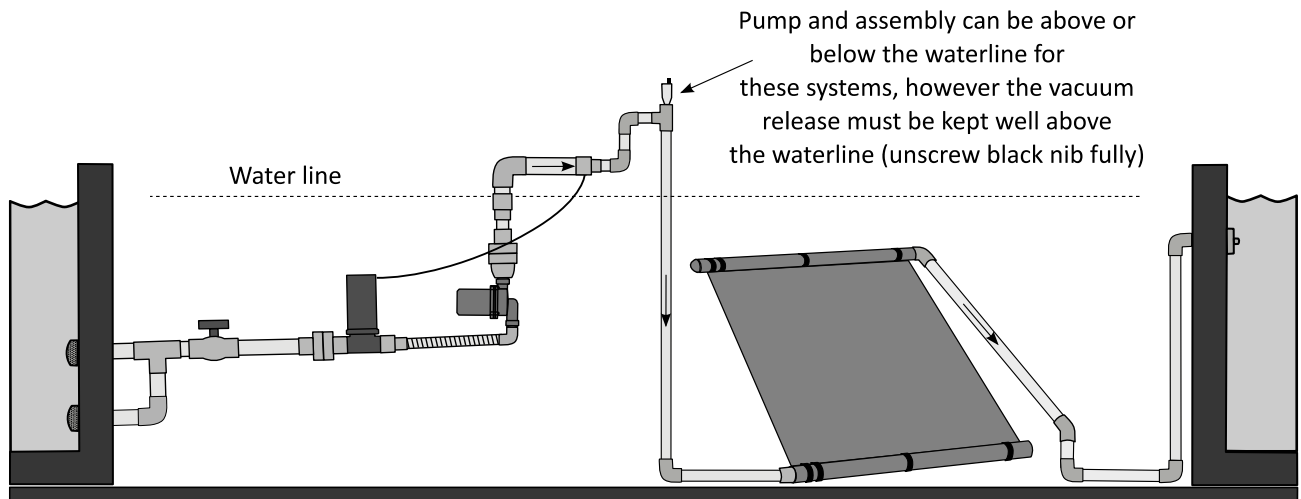

CAUTION

Below water level mounted collectors are allowed only in frost free areas, otherwise all collectors and plumbing lines must be frost tolerant. Collectors should not be mounted such that the lowest part is lower than 1m below the water line.



CAUTION

Below water level mounted collectors are subject to much harsher conditions than collectors that drain down. These conditions include constant positive pressure, 75°C stagnation temperatures in summer combined with constant exposure to hot chlorinated water and frost conditions. Extra maintenance to check collector and plumbing connection health must be carried out. Extra care must be taken to ensure pH is non-acidic, i.e. greater than 7.5.



WARNING

For below water level mounted collectors there is an increased risk of potential flooding resulting from the failure of the systems below water level plumbing connections or from extreme weather events. Extra care must be taken by the purchaser/installer, such that flood water from such a failure at any point of a Vertex system will drain safely.



DANGER

For ground mounted arrays, under no circumstances should a collector array be mounted in anyway so as to compromise the effectiveness of a pool or spa Child Safety Barrier.

25 Allowable Plumbing Variations

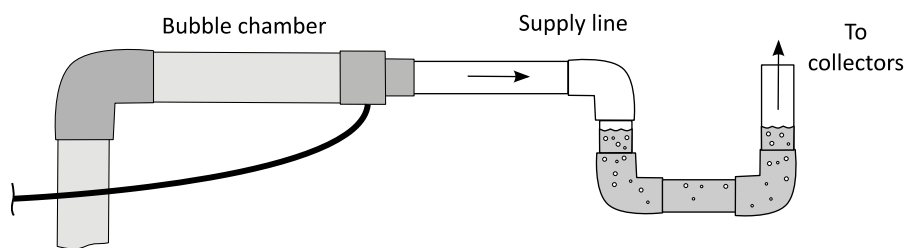
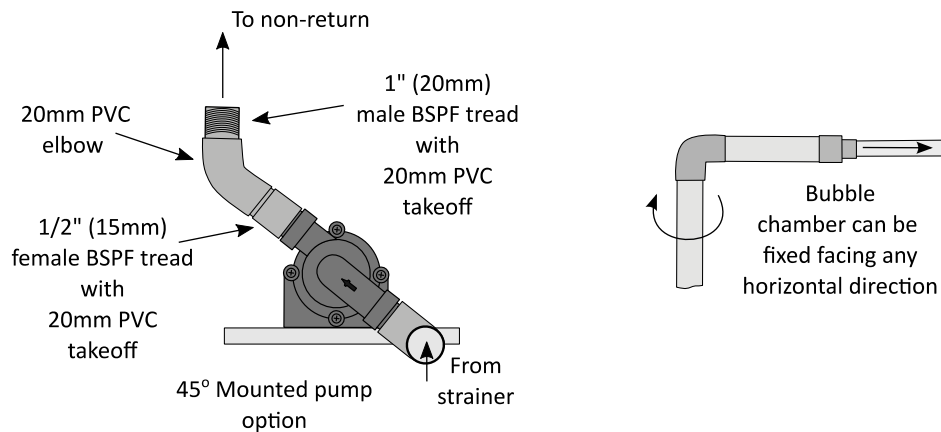

Any non-draining U-bends in the supply line will form an air trap and should be avoided if possible



Read Carefully

U-bends in the supply line will not drain fully and hence prevent air communication between the vacuum release and the pump assembly and should be avoided if at all possible. Preferably, all parts of the suction line should be mounted and sloped such that water empties fully up to the bubble chamber when the system stops.

25.1 Dual Pump Setups

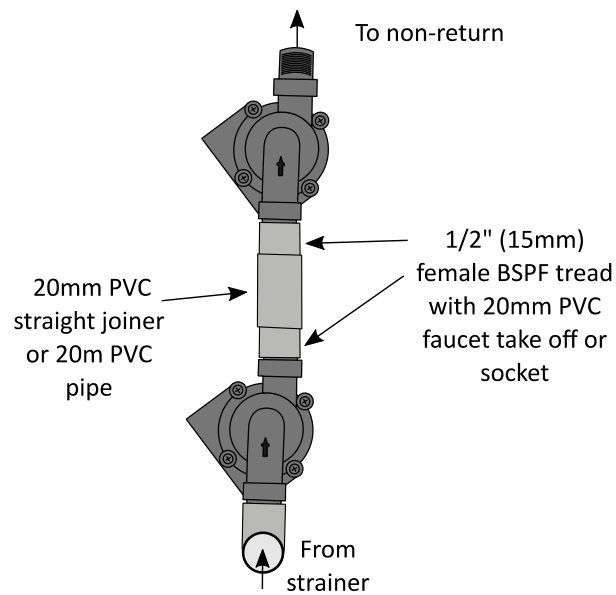

If your system came with dual pumps you can plumb them in vertically as shown or in a 45° configuration as shown in the previous section. For such dual pumps you'll also need to purchase 3 extra PVC bits; you can use 2 faucet take offs with a 20mm straight joiner or 2 faucet sockets with a 20mm PVC pipe for the interconnector between the pumps.

26 Solar PV Panel Mounting

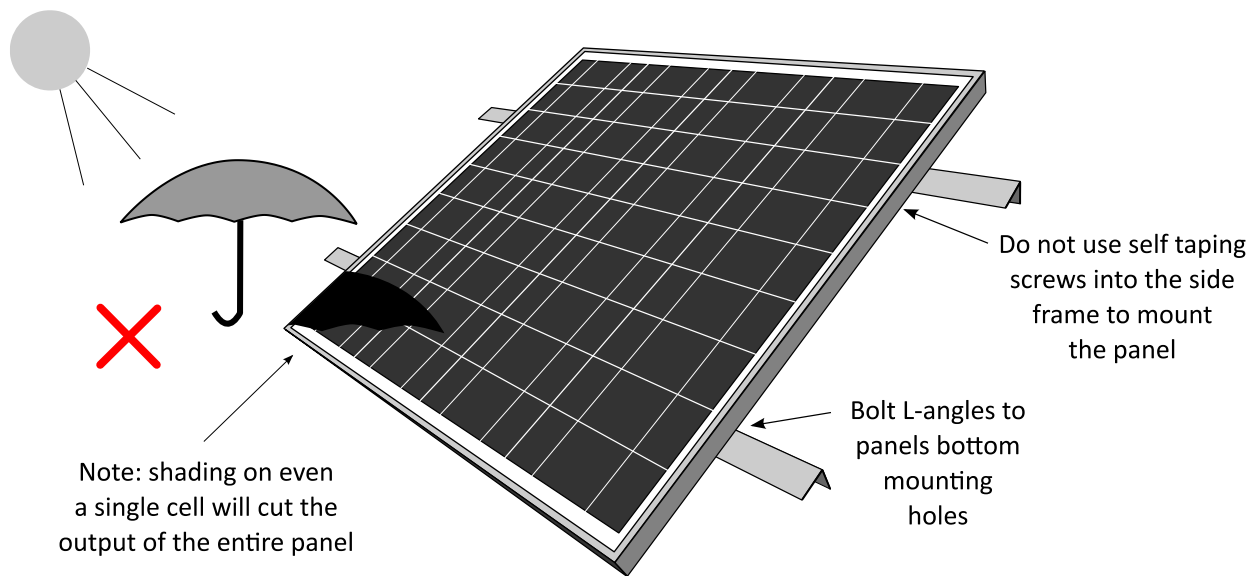

Read Carefully

The solar PV panel acts as a power source AND sun sensor for the thermal OKU collectors. Hence, the PV panel should be mounted at the same compass direction as the collector array, with the following exceptions:

- 1) For West or East facing thermal collector installations it is preferable that the PV panel face closer to NW or NE respectively.
- 2) For steep pitch thermal collector arrays it is preferable the PV panel be mounted on a shallower pitch to get more sun.

26.1 Solar PV Panel Location

For **ease of maintenance**, **short wire issues** and a **reduced chance of lighting strike** - we highly recommend that the solar panel is mounted **as close to the ground as possible** without running into shading issues.

26.2 Extending the Electrical Wires

The 5meter extension lead can be used to extend any of the three leads, i.e. the 1m pump lead, the 2m over-temperature lead or the 5m solar lead. Please note, we do not recommend further extensions as this will create too high a voltage drop. If a further extension is absolutely necessary we recommend you not use the 5m extension lead. Instead splice in a much higher gauge wire wherever required. You will need to purchase an appropriate splice kit at your local electrical supplier. If unsure we strongly recommend a qualified electrician splice wires together, as **bad electrical connections can form a fire hazard**.

27 Installing the Over-Temperature Thermostat



DANGER

Important: If the area of your collector array is oversized for your pool/spa and/or you have a highly insulated/covered pool/spa - you will require a safety thermostat to prevent the potential **overheating** of your pool/spa. The thermostat assembly should always be installed on the higher temperature **OUTLET (RETURN) SIDE** of the collector array.



DANGER

General Spa Pool Safety Notice: Prolonged bathing in hot water may increase a person's normal core body temperature of 37°C, which could result in hyperthermia. Persons affected by hyperthermia may experience, weakness, fainting, nausea, drowsiness, and muscle cramps - as a result, **they may experience a failure to perceive the impending danger of prolonged immersion and the need to exit the spa pool, and/or they may be physically unable to exit the spa pool.**

Using an accurate thermometer the spa pool owner should always check water temperatures do not exceed 40°C before allowing people to enter the spa pool. A water temperature of 38°C or lower is recommended for young children or pregnant women. Never use alcohol, drugs, or medication before entering a spa pool.



DANGER

As a precaution when working around a spa bath we recommend all **mains power be switched off**. The Vertex system is extra low voltage safe, however if you have any doubts about your ability to carry out electrical work on the Vertex system we recommend your wiring is installed and serviced by a qualified electrician.

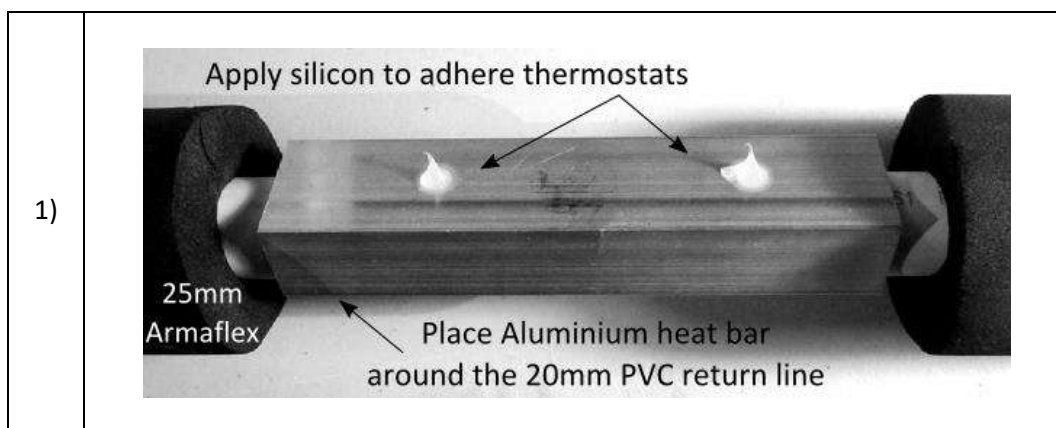

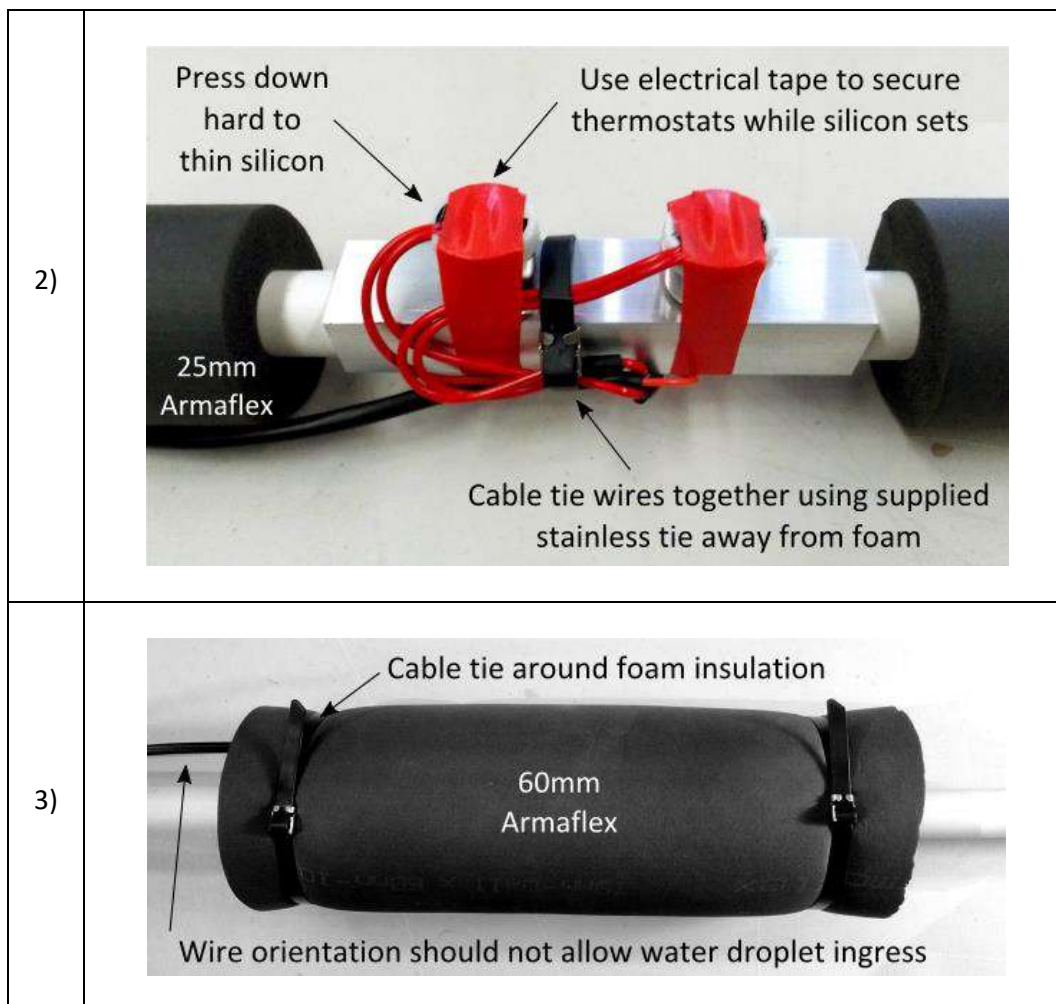

WARNING

Over-temperature thermostat assembly **MUST** be installed in a sheltered location away from rain and sun expose and in such a way that any water droplet condensation on pipes or wires cannot run inside the assembly.



WARNING

Adequate insulation of the Aluminium U-channel is required, otherwise the exposure of the U-channel to cooler external air may prevent the U-channel and hence the face of the thermostat from reaching the cut-off temperature.

The supplied 40°C thermostat (with secondary failsafe) will disconnect the pump(s) positive wire if the temperature of the water in the return line is about 40 to 42°C. The temperature differential across the solar collector array will mean that your spa temperature should be at or below 40°C during trigger.

27.1 Adjusting the Spa Temperature

If you require a lower spa temperature, we recommend you use ball valve (16) to constrict flow slightly. This will increase the temperature differential across the collector array and turn the system OFF faster.

28 Connecting the Inline Over-Temperature Thermostat and Extension Wire

The 5m extension cord can be used to extend the length of any connection

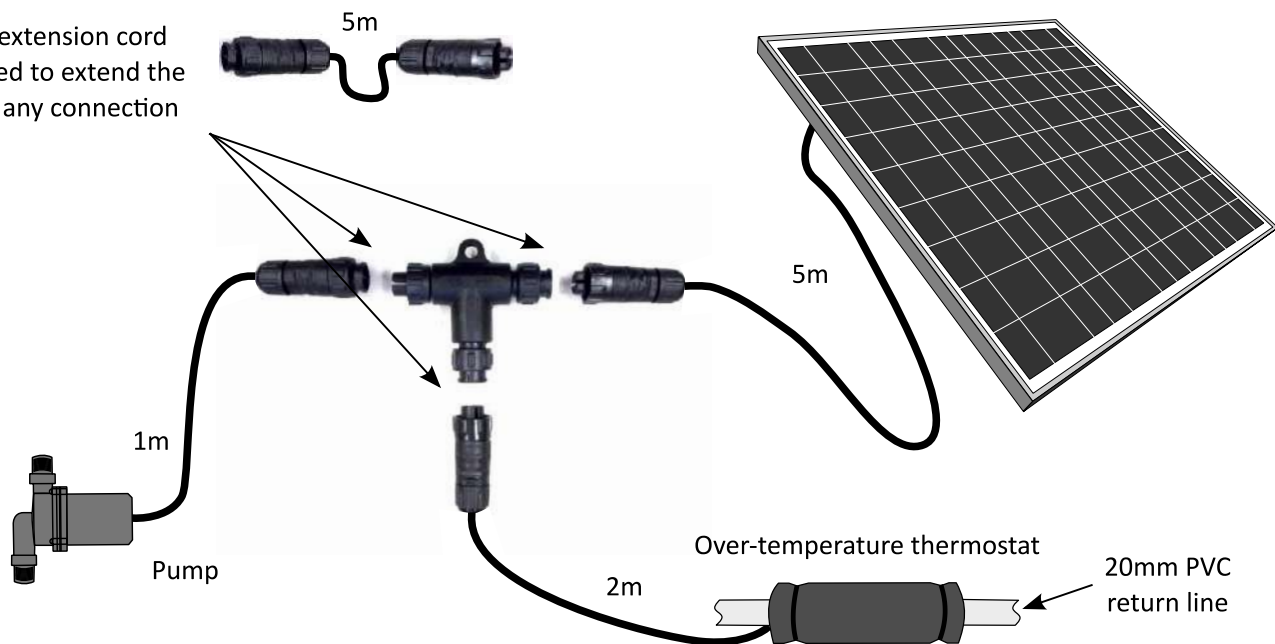

WARNING

The connectors should not be in a position such that they are continuously exposed to splashing spa water or rain ingress which can run down the cord and make its way inside the connector.



WARNING

The electrical system of the Vertex system cannot be modified in any way, such as for example the introduction of **any** alternate power supply other than the solar panel supplied. Vertex system electrical components cannot be used as part of any other modified system.



WARNING

Never run a 12-24V cable near or in the same compartment or conduit as other 240V cables due to the chance of mistaking the two cables at some later point in time during installation or servicing.



Read Carefully

Before turning ON the pump for the first time please refer to section **29 Switching the System ON for the First Time.**

29 Switching the System ON for the First Time

We recommend you wait till a sunny day and follow this procedure:

1. After the under-temperature thermostat has turned ON, connect the pump which will start in 3secs. Listen to the pump start - after an initial purge of air the pump should run smooth.
2. After 5 mins running disconnect the pump and let the system drain down for a few mins.
3. Reconnect the system and check that the pump starts smoothly, if not re-perform the above again.

If the pump does not start perfectly smoothly during this third start up, then air is getting into the pump and/or suction line during drain down. Check for air leaks or air traps.



CAUTION

If there is no sun available to perform this test, do not leave the pump connected. Do not let the system run for the first time unattended.

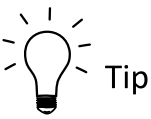

Tip

Sometimes an **air locked mode** can arise in the pump when a sufficiently large air bubble makes its way into the inlet of a working pump. In this state water cannot be pushed higher, nor can the column of water above the pump make its way back through the spinning rotor.

29.1 Check for Balanced Water Flow through All Collectors

1. With the sun shining on the collectors and the pump operational, run your hand over every part of each collector. Collectors should be cool to the touch while the top of each collector could be slightly warmer. **Hot spots indicate that there is no water flow through this part of the collector.**
2. To eliminate hot spots make sure the top header pipe of the entire collector array runs straight and that it has a slight slope (minimum 2°) with the outlet having the highest point. The inclination of the array may need to be increased.

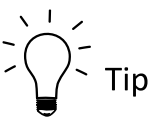

Tip

During full sun operation the outlet water flow should be strong with a temperature no greater than about 5-7°C that of the inlet.

29.2 Air Bubbles in the Return Port

If the eyelet return is not constrictive enough you may get some continuous bubbling into the spa while the system is running. (Note: air purging during system start is normal). Continuous bubbling can be reduced by introducing ball valve (16), see plumbing diagram section. Constrict this ball valve until you get less bubbling.

Constricting the flow in the system will also lower the maximum temperature the spa will get to before the over-temperature thermostat turns off the system.

30 Important Installation Check List

Your installation must have the following elements, see manual.

- The top header pipe was installed with a 1 to 2° slope toward the outlet.
- Aluminium channel was laid top and bottom of the collector array as shown in the manual.
- Ultimate uplift wind loadings were considered and panels secured appropriately.
- The stainless steel strapping was installed with sufficient play to allow for collector contraction.
- The roof edge exclusion zone was observed.
- A hot spot check was performed. All collectors are cool during full sun exposure (top of panels may be warmer).
- The PV panel is mounted with no shading and at least 2cm clearance from its mounting surface.
- The collector array faces anywhere from West to North East.
- A vacuum release valve was installed off the roof 750mm below the highest point of the collector array.
- The outlet is submersed in the pool/spa.
- A minimum of stress is placed on the pumps inlet/outlet pipe connections.
- All suction line prior to the pump is air tight and slopes up toward to the pump with no air traps.
- The over-temperature thermostat was installed and tested.
- The thermostat aluminium U-channel and thermostat itself is well insulated from the surroundings.
- PVC plumbing lines were laid at such an angle so that all water drains from them for frost proofing.
- The possibility of a drain down event caused by a failure in the Vertex plumbing lines was considered.
- A protective bypass line was installed under the 25mm PVC bubble chamber.

31 Further Operating Instructions



WARNING

Users should be made aware that under rare conditions on system start up, very hot water ~ 60°C will be ejected at the outlet return ports which has the potential to scold spa users. Users (especially children) should be advised to keep away from outlet during start up.



Read Carefully

If using the Vertex system for pools larger than 10m² we recommend that the filter pump run at least a short period in the evening so as to help mix the warm water deeper into the pool - otherwise the top layer of warm water will cool excessively at night.



CAUTION

We strongly recommend the system be switched off during pool/spa use or when you go on holidays. The system can be switched on after use, making sure people are away from the outlet and that the pump is still primed.

31.1 Legionaries Risk



WARNING

The Vertex system must be switched off 1 hour before spa use. Disinfectant should be introduced and the filter pump run for at least 1 hour before spa pool use. Always follow disinfection advice supplied by your spa pool manufacture.

32 Service and Maintenance Schedule



CAUTION

Important: before carrying out any system maintenance you **MUST** check for any manual and or technical service bulletin updates and download the latest installation manual from our Downloads Page: www.EcoOnline.com.au/downloads

The system strainer should be cleaned regularly depending on spa use.

Maintenance Issue - Service Procedure	1st Month	1st Quarter	Annual Checks	After 5 Years
Barb Plastic Relaxing - All the stainless steel hose clamps may need retightening as plastic relaxes overtime.	X		X	
Corroded or Fatigued Wiring – Wiring, solder connections and wire fixings should be checked for damage and/or corrosion signs.		X	X	
Silicon Joiner Chemical Attack – Disconnect a single silicon joiner, dry and check that the water exposed inside section has not turned grey or become unfirm to the touch. This would indicate chemical attack from a pH lower than 7. Replace as needed.		X	X	
Stainless Strap Fatigue - Inspect all stainless steel fixing straps for wear of PVC coating around the sharp Aluminium L-angle edge, which would indicate fatigue working of straps. Replace as needed.			X	
Mounting Frame - The integrity of the collector mounting frame and wind proofing components should be checked for any degradation. Replace as needed.			X	
Plumbing Degradation – Plumbing lines and fittings should be checked for signs of UV and/or chemical damage. Replace as needed.			X	
Vacuum Release Valve – The vacuum release valve is a critical system component. It should be checked that it is functioning correctly and that collectors are draining properly. The collector’s facets around weld points should never appear collapsed (concave) by negative pressure.			X	
Collector Plastic Contraction – Collectors can relax and contract by 10mm in length over the initial first few years. It should be checked that the stainless steel straps or fixings have not become too tight as a result. If required straps will need to be loosened slightly. This check should be carried out when the collectors are cool (water flowing).			X	
Debris Accumulation – Inspect the inner of the collectors. Depending on conditions collectors may need to be flushed with a suitable cleaning agent for debris accumulation after many years of use.				X



WARNING

Fatigued, weathered, loose and/or corroded wiring or electrical connections poses a fire risk even at low voltage.

32.1 Collector Puncture Repair Procedure

Drill out the puncture using a sharp drill bit (being careful not to drill into the opposite wall). Inject chlorine resistant pool silicon into the collector inner to create a ~10cm inner silicon disk plug. Wait one day before re-pressurizing.

33 Trouble Shooting

Problem	Cause	Solution
Pump is running smoothly but no water is coming out of the spa outlet.	<ul style="list-style-type: none"> * Morning light is not strong enough to reach the pump height * There is a blockage or the PVC ball valve is closed * Pump height is too high 	<ul style="list-style-type: none"> * Check for blockages or open PVC ball valve * Wait for 11am-3am sun (for a North install) * There maybe U bend air traps in the plumbing lines which are adding to the pump height, these should be removed. * Failing these points a stronger pump may be required.
Pump is running loudly, like it's churning air/water mixture	Air bubbles making their way through the pump	<ul style="list-style-type: none"> * Check for air traps or air leaks before the filter.
Some of the collectors are hot when the sun is shining and the pump is running fully	Water is not flowing evenly through all collectors	<ul style="list-style-type: none"> * Make sure the header pipe is sloped toward the outlet. * Panels should be mounted with a minimum 5-10 degree pitch to remove surface air bubbles.
The outlet flow is strong and the system is working but the pool is not warm enough	Potentially undersized system	<ul style="list-style-type: none"> * Check for balanced water flow through all collectors. If collectors are coolish in full sun, then the system is undersized. Note: in ground pools need a week before fully temperature is reached. Consider using a solar blanket, or add more collectors.
The outlet water flow is low and the outlet water is very warm to hot during operation	Potentially undersized pump configuration, or flow restriction, or U-bends adding to pump height	<ul style="list-style-type: none"> * Check for blockages or water flow restrictions and the ability of the chosen pump configuration to pump strongly up to the required height. A larger pump configuration may be required.
The solar panel is in full sun and is connected to the pump however the pump is not working.	<ul style="list-style-type: none"> * The under-temperature thermostat may have not come to temperature yet. * Potentially faulty, pump, solar panel, or thermostat switch, or rotor blockage in the pump. 	<ul style="list-style-type: none"> *Check the power of PV panel first by inserting a standard (GX5.3 base) 12V Halogen globe into the connector pins. * Check the pump by connecting to a 18VDC battery * If the pump has been exposed to potential particles in the water the rotor could be blocked - dissemble the pump slowly on a clean table (take note of the assembly) clean any blockages.
When the system is running air bubbles do not stop appearing at the outlet	<ul style="list-style-type: none"> * Air leak in the suction and/or array inlet lines * Negative pressure at vacuum breaker valve 	<ul style="list-style-type: none"> *Check all connections on the suction, pump and array inlet line and make sure they are air tight. * Install a brake ball valve in the return line to increase back pressure, constrict until bubble decrease
The system overheated my spa/pool past 40°C	Faulty or inadequately insulated thermostat assembly	<ul style="list-style-type: none"> *Check that the thermostat is working by heating the aluminium U channel to 45-50°C (keeping the thermostat switch dry).
The system turns off midday below my preferred temperature	Reduced flow rate or larger panel arrays create a large temperature differential triggering the over-temperature thermostat early	<ul style="list-style-type: none"> * Check plumbing for blockages and/or air locks. You may need a stronger pump for more flow. Else contact info@ecoonline.com.au on this issue.
The system is warming my spa beyond my preferred temperature	Too much water flow	<ul style="list-style-type: none"> * Temperature adjustments on the Vertex system are made via flow restrictions, install a brake ball valve in the return line to decrease flow and trigger the over-temp thermostat earlier.